



NV... Non-Spring Return
 On/Off, floating:
 NV24-3 US
 Proportional (2-10 VDC Default):
 NV24-MFT US

NVF... Spring Return
 Proportional (2-10 VDC Default)
 On/Off, floating:
 NVF24-MFT US Spring Up
 NVF24-MFT-E US Spring Down

Control: On/Off, floating,
 2-10 VDC
**Multi-Function
 Technology®**
 Spring Return or
 Non-Spring Return

G2 Series Two-way
G2 ...S Two-way
 Stainless trim
G3 Series Three-way
 Mixing
G3...D Series Three-way
 Diverting

1/2" to 2"

Service: Chilled/hot water,
 60% glycol
C_v Range: .4-40 (2-way)
 2.2-41 (3-way Mix.)
 4.4-40 (3-way Div.)
Material: Stainless stem,
 Brass plug or
 Stainless plug
Control: On/Off, floating,
 2-10 VDC
**Multi-Function
 Technology®**
 Spring Return or
 Non-Spring Return

Feature	Benefit
NV Series Direct Coupled Globe Valve Actuator / G2...,G3..., G3...D Series Globe Valves	
Self-adjusting stroke resolution	Utilizes full control signal for maximum resolution
Visual sliding stroke indicators - Position indicators adjusted automatically	Speeds installation and system check
Assembly can be mounted with valve stem horizontal to the pipe	Piping flexibility
Self locking valve coupling	Proper valve-actuator connection is ensured

NV Series Globe Valve Actuator Technology

A new generation of linear actuators

The robust and compact NV... actuators that have been specially designed for use with globe valves from 1/2" to 2" are setting new standards in the industry in terms of functionality, ease of installation and economy.

- Outstanding precision and reliability thanks to the use of a brushless electronic motor.
- An optional integral spring assembly for the automatic triggering of the emergency control function.
- A very simple connection between valve and actuator allowing the easiest possible installation without any special tools or devices.
- Designed with Multi-Function Technology® (MFT) allowing simple mechanical and electrical to various control signals.
- Compact, modular construction making the actuators ideal for use with many other makes of valve.
- Non-Spring Return and Spring Return Models.
- Self-adjusting stroke utilizes full control signal for maximum resolution.
- Easy actuator retrofit or new installation on valves.
- Assembly can be mounted with valve stem horizontal to the pipe.



■ Set, modify or read:

CONTROL

- Pulse Width Modulation
- Start/Stop Adjustable
- Floating Point
- On/Off
- Feedback

MOTION

- Running time
- Force
- Stroke

DIAGNOSTICS

- Hunting
- Mechanical Overload
- Over-Travel
- Load Limit

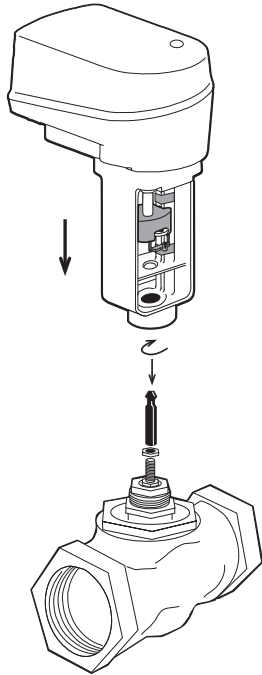

- 1** Attach stem adaptor, and screw NV onto valve body.

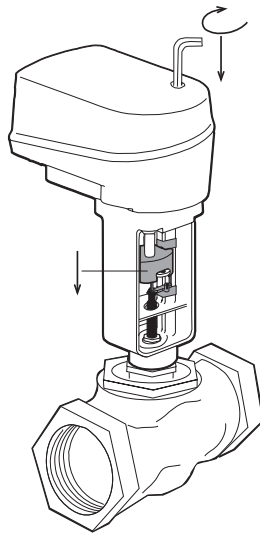

- 2** Use hex, screwdriver or power supply to move valve coupling down toward stem.

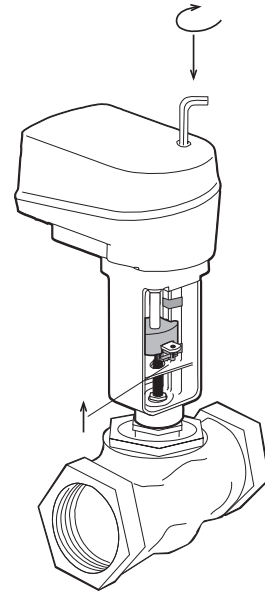

- 3** When actuator is securely attached to stem, the locking mechanism will pop out from the valve coupling. Press pin into locking mechanism to secure.

NV Series Globe Valve Actuator Technology

Nomenclature:

NVFD24-MFT-E US

N	V	F	D	24	-MFT	-E	US
Force 180 lbf	Valve Actuator (Linear)	Spring Return Fail Safe	Reduced Force (90 lbf)	24 VAC/DC power	Multi- Function Technology® (2 to 10 VDC or Custom)	Extending, spring down	

NV Series Actuators Models:

	Model	Description	Valve size	Note
Non-Spring Return	NV24-3 US	on/off, floating point	1" to 2"	One model for on/off and floating point
	NVD24-3 US	on/off, floating point, reduced force	1/2" to 3/4"	
	NV24-MFT US	2-10 VDC (default)	1" to 2"	For custom: specify PWM range when ordering. (See V-codes)
	NVD24-MFT US	2-10 VDC (default), reduced force	1/2" to 3/4"	
Spring Return	NVFD24 US	on/off, reduced force, spring up	1/2" to 3/4"	One model for on/off only
	NVFD24-E US	on/off, reduced force, spring down	1/2" to 3/4"	
	NVFD24-MFT US†	2-10 VDC (default), reduced force, spring up	1/2" to 3/4"	For custom: specify PWM range or floating point when ordering. (See V-codes)
	NVFD24-MFT-E US†	2-10 VDC (default), reduced force, spring down	1/2" to 3/4"	
	NVF24-MFT US†	2-10 VDC (default), spring up	1" to 2"	For custom: specify PWM range, floating point or on/off when ordering. (See V-codes)
	NVF24-MFT-E US†	2-10 VDC (default), spring down	1" to 2"	

Multi-Function Technology For complete technical information refer to Product Documentation Multi-Function Technology®

Model	Power Supply	Control Input	Feedback
V-10001	24VAC/DC	2-10 VDC (4-20 mA)*	2-10 VDC
V-10002	24 VAC/DC	0-10 VDC	0-10 VDC
V-10003	24 VAC/DC	2-10 VDC	0-5 VDC
V-10004	24 VAC/DC	4-7 VDC	2-10 VDC
V-10005	24 VAC/DC	6-9 VDC	2-10 VDC
V-10006	24 VAC/DC	10.5-13.5 VDC	2-10 VDC
V-10012	24 VAC/DC	0-5 VDC	0-2.5 VDC
V-20001	24 VAC/DC	0.59-2.93 sec. PWM	2-10 VDC
V-20002	24 VAC/DC	0.02-5.00 sec. PWM	2-10 VDC
V-20003	24 VAC/DC	0.10-25.5 sec. PWM	2-10 VDC
V-30001	24 VAC/DC	Floating Point	2-10 VDC
V-40002	24 VAC/DC	On/Off	2-10 VDC

* With 500Ω resistor

Example: NVF24-MFT US is the basic model. Add the V... pre-set MFT configuration number and list price to the actuator when ordering, as needed.

† Specify when ordering proportional (V-10001), floating point (V-30001), on/off (V-40002) – no additional cost

Electronic Globe Valves



G2 and G2...S Series Globe Valves, NV Series Spring Return Actuator



NVF...
NVFD...
with G2...



NVF...
NVFD...
with G2...S
(Stainless trim)

G2 Two-Way Globe Valve with NVF... Spring Return



Valve					Spring Return Actuator			
Model #	Cv Rating	Valve Nominal Size		Close-Off psi	NVFD and NVF Actuator Fail Open (Spring Up)		NVFD and NVF Actuator Fail Closed (Spring Down)	
		Inches	DN mm		On/Off	On/Off / Floating Proportional / MFT	On/Off	On/Off / Floating Proportional / MFT
Valve					NVFD24 US	NVFD24-MFT US†	NVFD24-E US	NVFD24-MFT-E US†
G212	0.4	1/2"	15	250	●	●	●	●
G213	1.3	1/2"	15	250	●	●	●	●
G214	2.2	1/2"	15	250	●	●	●	●
G215	4.4	1/2"	15	250	●	●	●	●
G219	5.5	3/4"	20	250	●	●	●	●
G220	7.5	3/4"	20	250	●	●	●	●
G224	10	1"	25	207		●		●
G225	14	1"	25	207		●		●
G232	20	1-1/4"	32	130		●		●
G240	28	1-1/2"	40	88		●		●
G250	40	2"	50	47		●		●

† Specify when ordering proportional (V-10001), floating point (V-30001), on/off (V-40002) – no additional cost



G2...S Two-Way Globe Valve SS trim, with NVF... Spring Return

Valve					Spring Return Actuator			
Model #	Cv Rating	Valve Nominal Size		Close-Off psi	NVFD and NVF Actuator Fail Open (Spring Up)		NVFD and NVF Actuator Fail Closed (Spring Down)	
		Inches	DN mm		On/Off	On/Off / Floating Proportional / MFT	On/Off	On/Off / Floating Proportional / MFT
Valve					NVFD24 US	NVFD24-MFT US†	NVFD24-E US	NVFD24-MFT-E US†
G212S	0.4	1/2"	15	250	●	●	●	●
G213S	1.3	1/2"	15	250	●	●	●	●
G214S	2.2	1/2"	15	250	●	●	●	●
G215S	4.4	1/2"	15	250	●	●	●	●
G219S	5.5	3/4"	20	250	●	●	●	●
G220S	7.5	3/4"	20	250	●	●	●	●
G224S	10	1"	25	207		●		●
G225S	14	1"	25	207		●		●
G232S	20	1-1/4"	32	130		●		●
G240S	28	1-1/2"	40	88		●		●
G250S	40	2"	50	47		●		●

† Specify when ordering proportional (V-10001), floating point (V-30001), on/off (V-40002) – no additional cost

Multi-Function Technology

For complete technical information refer to Product Documentation Multi-Function Technology®

Model	Power Supply	Control Input	Feedback
V-10001	24VAC/DC	2-10 VDC (4-20 mA)*	2-10 VDC
V-10002	24 VAC/DC	0-10 VDC	0-10 VDC
V-10003	24 VAC/DC	2-10 VDC	0-5 VDC
V-10004	24 VAC/DC	4-7 VDC	2-10 VDC
V-10005	24 VAC/DC	6-9 VDC	2-10 VDC
V-10006	24 VAC/DC	10.5-13.5 VDC	2-10 VDC
V-10012	24 VAC/DC	0-5 VDC	0-2.5 VDC
V-20001	24 VAC/DC	0.59-2.93 sec. PWM	2-10 VDC
V-20002	24 VAC/DC	0.02-5.00 sec. PWM	2-10 VDC
V-20003	24 VAC/DC	0.10-25.5 sec. PWM	2-10 VDC
V-30001	24 VAC/DC	Floating Point	2-10 VDC
V-40002	24 VAC/DC	On/Off	2-10 VDC

*With 500Ω resistor

Example: NVF24-MFT US is the basic model. Add the V... pre-set MFT configuration number and list price to the actuator when ordering, as needed.

† Specify when ordering proportional (V-10001), floating point (V-30001), on/off (V-40002) – no additional cost



G3 Three-Way **Mixing** Globe Valve with NVF... Spring Return

Valve					Spring Return Actuator			
Model #	Cv Rating	Valve Nominal Size		Close-Off psi	NVFD and NVF Actuator Fail Closed (Spring Up)		NVFD and NVF Actuator Fail Open (Spring Down)	
		Inches	DN mm		On/Off	On/Off / Floating Proportional / MFT	On/Off	On/Off / Floating Proportional / MFT
Valve					NVFD24 US	NVFD24-MFT US† NVF24-MFT US†	NVFD24-E US	NVFD24-MFT-E US† NVF24-MFT-E US†
G314	2.2	1/2"	15	250	●	●	●	●
G315	4.4	1/2"	15	250	●	●	●	●
G320	7.5	3/4"	20	250	●	●	●	●
G325	14	1"	25	207		●		●
G332	20	1-1/4"	32	130		●		●
G340	28	1-1/2"	40	88		●		●
G350	41	2"	50	47		●		●

† Specify when ordering proportional (V-10001), floating point (V-30001), on/off (V-40002) – no additional cost



G3...D Three-Way **Diverting** Globe Valve with NVF... Spring Return

Valve					Spring Return Actuator			
Model #	Cv Rating	Valve Nominal Size		Close-Off psi	NVFD and NVF Actuator Fail Closed (Spring Up)		NVFD and NVF Actuator Fail Open (Spring Down)	
		Inches	DN mm		On/Off	On/Off / Floating Proportional / MFT	On/Off	On/Off / Floating Proportional / MFT
Valve					NVFD24 US	NVFD24-MFT US† NVF24-MFT US†	NVFD24-E US	NVFD24-MFT-E US† NVF24-MFT-E US†
G315D	4.4	1/2"	15	250	●	●	●	●
G320D	7.5	3/4"	20	250	●	●	●	●
G325D	15	1"	25	250		●		●
G332D	20	1-1/4"	32	250		●		●
G340D	28	1-1/2"	40	250		●		●
G350D	40	2"	50	250		●		●

† Specify when ordering proportional (V-10001), floating point (V-30001), on/off (V-40002) – no additional cost

Multi-Function Technology For complete technical information refer to Product Documentation Multi-Function Technology®

Model	Power Supply	Control Input	Feedback
V-10001	24 VAC/DC	2-10 VDC (4-20 mA)*	2-10 VDC
V-10002	24 VAC/DC	0-10 VDC	0-10 VDC
V-10003	24 VAC/DC	2-10 VDC	0-5 VDC
V-10004	24 VAC/DC	4-7 VDC	2-10 VDC
V-10005	24 VAC/DC	6-9 VDC	2-10 VDC
V-10006	24 VAC/DC	10.5-13.5 VDC	2-10 VDC
V-10012	24 VAC/DC	0-5 VDC	0-2.5 VDC
V-20001	24 VAC/DC	0.59-2.93 sec. PWM	2-10 VDC
V-20002	24 VAC/DC	0.02-5.00 sec. PWM	2-10 VDC
V-20003	24 VAC/DC	0.10-25.5 sec. PWM	2-10 VDC
V-30001	24 VAC/DC	Floating Point	2-10 VDC
V-40002	24 VAC/DC	On/Off	2-10 VDC

* With 500Ω resistor

Example: NVF24-MFT US is the basic model. Add the V... pre-set MFT configuration number and list price to the actuator when ordering, as needed.

† Specify when ordering proportional (V-10001), floating point (V-30001), on/off (V-40002) – no additional cost

Electronic Globe Valves



G2 and G2...S Series Globe Valves, NV Series Non-Spring Return Actuator



G2 Two-Way Globe Valve with NV... Non-Spring Return

Model #	Cv Rating	Valve Nominal Size		Close-Off psi	Non-Spring Return Actuator		
					On/Off, Floating		Proportional / MFT
					NVD24-3 US		NVD24-MFT US†
					NV24-3 US		NV24-MFT US†
Valve		Inches	DN mm				
G212	0.4	1/2"	15	250	●	●	●
G213	1.3	1/2"	15	250	●	●	●
G214	2.2	1/2"	15	250	●	●	●
G215	4.4	1/2"	15	250	●	●	●
G219	5.5	3/4"	20	250	●	●	●
G220	7.5	3/4"	20	250	●	●	●
G224	10	1"	25	207	●	●	●
G225	14	1"	25	207	●	●	●
G232	20	1-1/4"	32	130	●	●	●
G240	28	1-1/2"	40	88	●	●	●
G250	40	2"	50	47	●	●	●

† Specify when ordering proportional (V-10001), floating point (V-30001), on/off (V-40002) – no additional cost

G2...S Two-Way Globe SS Trim, NPT Valve with NV... Non-Spring Return

Model #	Cv Rating	Valve Nominal Size		Close-Off psi	Non-Spring Return Actuator		
					On/Off, Floating		Proportional / MFT
					NVD24-3 US		NVD24-MFT US†
					NV24-3 US		NV24-MFT US†
Valve		Inches	DN mm				
G212S	0.4	1/2"	15	250	●	●	●
G213S	1.3	1/2"	15	250	●	●	●
G214S	2.2	1/2"	15	250	●	●	●
G215S	4.4	1/2"	15	250	●	●	●
G219S	5.5	3/4"	20	250	●	●	●
G220S	7.5	3/4"	20	250	●	●	●
G224S	10	1"	25	207	●	●	●
G225S	14	1"	25	207	●	●	●
G232S	20	1-1/4"	32	130	●	●	●
G240S	28	1-1/2"	40	88	●	●	●
G250S	40	2"	50	47	●	●	●

† Specify when ordering proportional (V-10001), floating point (V-30001), on/off (V-40002) – no additional cost

Multi-Function Technology For complete technical information refer to Product Documentation Multi-Function Technology®

Model	Power Supply	Control Input	Feedback
V-10001	24VAC/DC	2-10 VDC	2-10 VDC (4-20 mA)*
V-10002	24 VAC/DC	0-10 VDC	0-10 VDC
V-10003	24 VAC/DC	2-10 VDC	0-5 VDC
V-10004	24 VAC/DC	4-7 VDC	2-10 VDC
V-10005	24 VAC/DC	6-9 VDC	2-10 VDC
V-10006	24 VAC/DC	10.5-13.5 VDC	2-10 VDC
V-10012	24 VAC/DC	0-5 VDC	0-2.5 VDC
V-20001	24 VAC/DC	0.59-2.93 sec. PWM	2-10 VDC
V-20002	24 VAC/DC	0.02-5.00 sec. PWM	2-10 VDC
V-20003	24 VAC/DC	0.10-25.5 sec. PWM	2-10 VDC
V-30001	24 VAC/DC	Floating Point	2-10 VDC
V-40002	24 VAC/DC	On/Off	2-10 VDC

* With 500Ω resistor Example: NV24-MFT US is the basic model. Add the V... pre-set MFT configuration number and list price to the actuator when ordering, as needed.

† Specify when ordering proportional (V-10001), floating point (V-30001), on/off (V-40002) – no additional cost



G3 Three-Way **Mixing** Globe Valve with NV Non-Spring Return

Model #	Cv Rating	Valve		Close-Off psi	Non-Spring Return Actuator	
		Nominal Size Inches	DN mm		On/Off, Floating	Floating, Proportional / MFT
Valve					NVD24-3 US	NVD24-MFT US†
					NV24-3 US	NV24-MFT US†
G314	2.2	1/2"	15	250	●	●
G315	4.4	1/2"	15	250	●	●
G320	7.5	3/4"	20	250	●	●
G325	14	1"	25	207	●	●
G332	20	1-1/4"	32	130	●	●
G340	28	1-1/2"	40	88	●	●
G350	41	2"	50	47	●	●

† Specify when ordering proportional (V-10001), floating point (V-30001), on/off (V-40002) – no additional cost



G3...D Three-Way **Diverting** Globe Valve with NV Non-Spring Return

Model #	Cv Rating	Valve		Close-Off psi	Non-Spring Return Actuator	
		Nominal Size Inches	DN mm		On/Off, Floating	Floating, Proportional / MFT
Valve					NVD24-3 US	NVD24-MFT US†
					NV24-3 US	NV24-MFT US†
G315D	4.4	1/2"	15	250	●	●
G320D	7.5	3/4"	20	250	●	●
G325D	15	1"	25	250	●	●
G332D	20	1-1/4"	32	250	●	●
G340D	28	1-1/2"	40	250	●	●
G350D	40	2"	50	250	●	●

† Specify when ordering proportional (V-10001), floating point (V-30001), on/off (V-40002) – no additional cost

Multi-Function Technology

For complete technical information refer to Product Documentation Multi-Function Technology®

Model	Power Supply	Control Input	Feedback
V-10001	24VAC/DC	2-10 VDC (4-20 mA)*	2-10 VDC
V-10002	24 VAC/DC	0-10 VDC	0-10 VDC
V-10003	24 VAC/DC	2-10 VDC	0-5 VDC
V-10004	24 VAC/DC	4-7 VDC	2-10 VDC
V-10005	24 VAC/DC	6-9 VDC	2-10 VDC
V-10006	24 VAC/DC	10.5-13.5 VDC	2-10 VDC
V-10012	24 VAC/DC	0-5 VDC	0-2.5 VDC
V-20001	24 VAC/DC	0.59-2.93 sec. PWM	2-10 VDC
V-20002	24 VAC/DC	0.02-5.00 sec. PWM	2-10 VDC
V-20003	24 VAC/DC	0.10-25.5 sec. PWM	2-10 VDC
V-30001	24 VAC/DC	Floating Point	2-10 VDC
V-40002	24 VAC/DC	On/Off	2-10 VDC

* With 500Ω resistor

Example: NV24-MFT US is the basic model. Add the V... pre-set MFT configuration number and list price to the actuator when ordering, as needed.

† Specify when ordering proportional (V-10001), floating point (V-30001), on/off (V-40002) – no additional cost

Electronic Globe Valves



UNV Series Retrofit Kits

Application

UNV Series Retrofit Kits are designed for use with NV Series actuators.

These kits include all parts needed to mount to any of the below valves (see chart).

NV actuators are purchased separately.



Valve Manufacturer	Valve Body	Size	Kit	Stem Adjustment*
SIEBE / Invensys	VB7000 – 2 way and 3 way	1/2" to 2"	UNV-001	45 mm
	VB9000 – 2 way and 3 way	1/2" to 1.25"	UNV-001	44 mm
	Belimo USA G2 Series – 2 way	1/2" to 2"	UNV-001	45 mm
	Belimo USA G3 Series – 3 way	1/2" to 2"	UNV-001	45 mm
Danfoss-Trata	Belimo Europe Series H4 – 2 way	1/2" to 2"	UNV-002	–
	Belimo Europe Series H5 – 3 way	1/2" to 2"	UNV-002	–
Siemens	VF 599 Series – 2 way	1/2" to 2"	UNV-003	No adjustment needed
	VF 599 Series – 3 way	1/2" to 2"	UNV-003	No adjustment needed
Landis and Gyr (Powers)	Powertop/Series VP 658 – 2 way and 3 way	1/2" to 1.25"	UNV-004	60 mm
	Flowrite/Series VP591 – 2 way	1/2" to 1"	UNV-005	65 mm
	Flowrite/Series VP591 – 3 way	1/2" to 2"	UNV-005	65 mm
Honeywell	V5011 Series – 2 way – screwed	1/2" to 3"	UNV-006	65 mm
	V5013 Series – 3 way – screwed	1/2" to 3"	UNV-006	65 mm
	V5011N Series – 2 way	1/2" to 3"	UNV-006	65 mm
	V5013N Series – 3 way	1/2" to 3"	UNV-006	65 mm
Robertshaw	V6600 – 3 way	1/2" to 2"	UNV-007	60 mm
	V6700 – 2 way	1/2" to 2"	UNV-007	60 mm
	V6800 – 2 way	3/4"	UNV-007	64 mm
Johnson Controls	V-3754 Series Bronze Cage Trim – 2 way	3/4" to 2"	UNV-008	60 mm
	V-3974 Series Bronze Cage Trim – 2 way	3/4" to 2"	UNV-008	60 mm
	V-4324 Series Bronze Cage Trim – 3 way	3/4" to 2"	UNV-008	60 mm
	V-5844 Series – 2 and 3 way	3/4" to 2"	UNV-008	60 mm
	VG7000 Series – 2 and 3 way	1/2" to 3/4"	UNV-009	65 mm
SIEBE / Invensys For steam use up to 50 psi inlet pressure	VB7000 – 2 way	1/2" to 2"	UNV-035	67 mm
	VB9000 – 2 way	1/2" to 1.25"	UNV-035	66 mm
	Belimo USA G2...S Series – 2 way	1/2" to 2"	UNV-035	67 mm

*For installation see pages 46 and 47.

UNV-001 Dimensions in inches (numbers in brackets are metric)

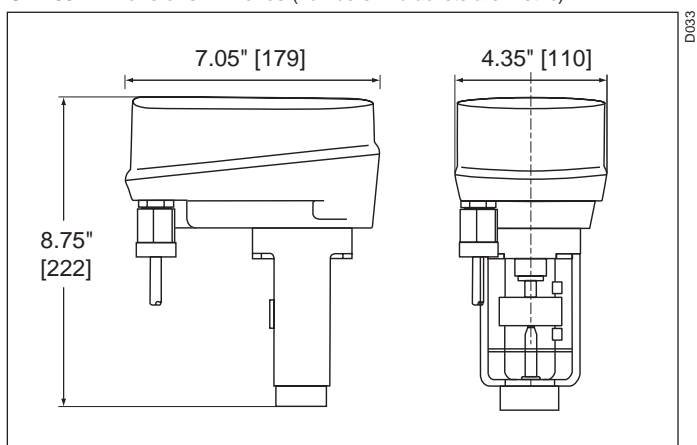

UNV-003-UNV-035 Dimensions in inches (numbers in brackets are metric)

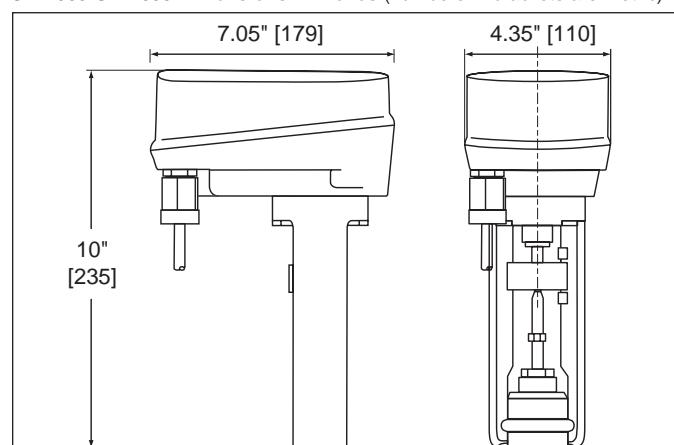

E20222 5 4 3 2 1 05/02-10M-FG-Subject to change. © Belimo Aircontrols (USA), Inc.

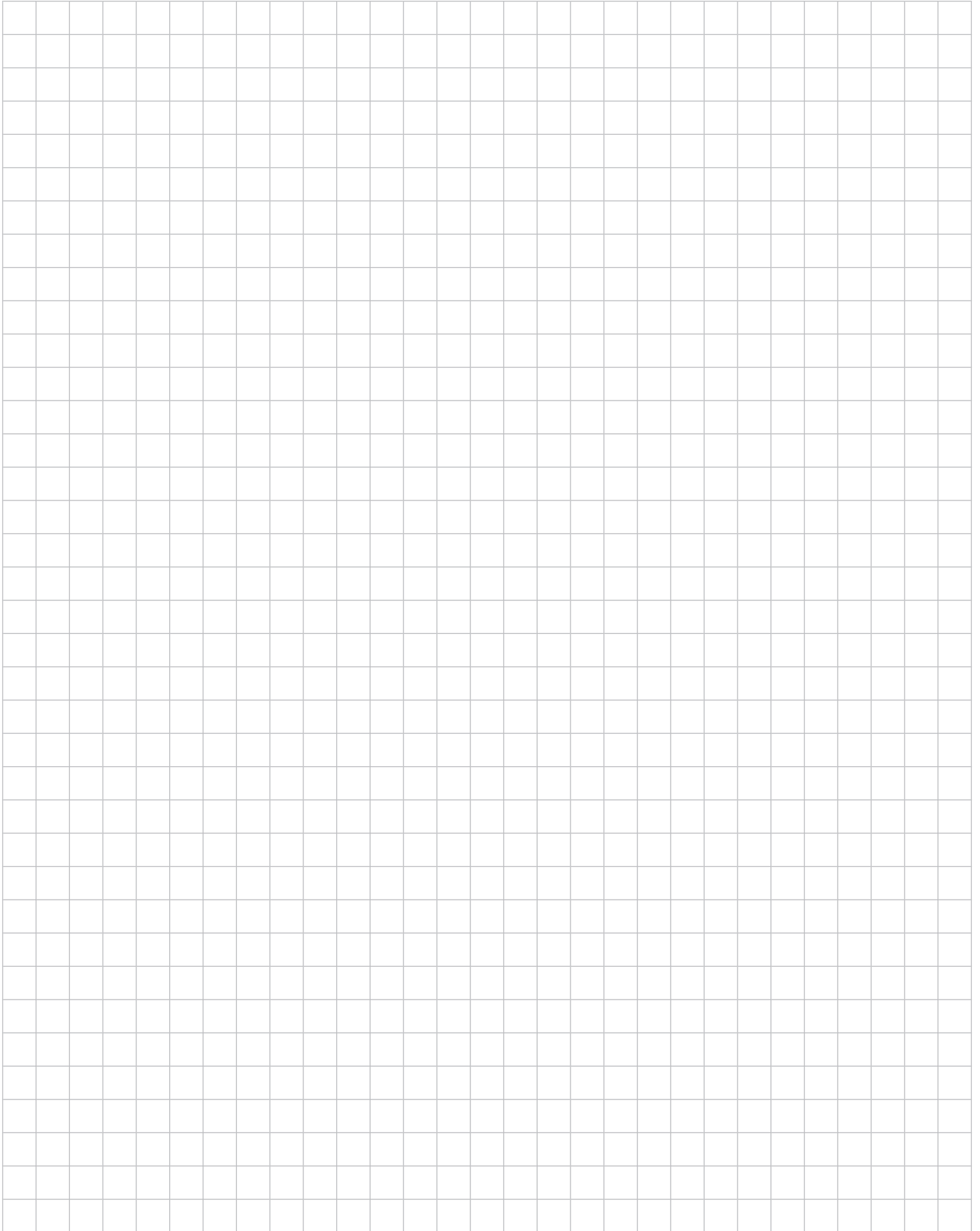

Electronic Globe Valves

NV(D)24-MFT US Non-spring return, direct coupled globe valve actuator, proportional control



NV24-MFT US NVD24-MFT US

Application

For floating point and proportional control of globe valves. Actuator will mate to an integrated adaptor bracket. Adaptor bracket shown fits valves manufactured by Siebe Environmental Controls under designations VB7000 and VB9000.

Functional safety

The actuator is secured against short circuiting and incorrect polarity. The stroke is adapted automatically and is overload-protected.

Manual operation

When a 3/16" or 5 mm hex is inserted and turned clockwise, the actuator plunger pushes out. The actuator plunger retains the position until the nominal voltage is applied.

Display of function

The stroke is shown mechanically on the adaptor bracket, and the maximum stroke is set automatically. Under the housing cover on -MFT models is a two-colored LED status display.

Multi-Function Technology® (MFT)

An integrated microprocessor allows for a variety of parameters to be easily configured at the factory or in the field.

Technical Data	NV... Series
Power Supply:	24 VAC +/- 20% 50/60 Hz 24 VDC +/- 10%
Power consumption	5 W, NV...-MFT US
Transformer sizing	7 VA, NV...-MFT US (Class 2 power supply)
Electrical connection	3 ft, 18 GA appliance cable, 1/2" conduit fitting
Overload protection	electronic throughout stroke
Control signal Y*	2 to 10 VDC, NV...MFT US, V-10001 Default Pulse width modulation, NV...MFT US V-20... (selectable when ordered)
Operating range*	2 to 10 VDC, 4 to 20 mA w/500Ω, 1/4" W resistor
Input impedance	100KΩ for 2 to 10 VDC, 500Ω for 4 to 20 mA, 750Ω for PWM 1500Ω for On-Off, Floating point, NV...3 US
Feedback*	2 to 10 VDC, 0.5 mA max., NV...MFT US
Maximum stroke	3/4" [20 mm]
Force	90 lbf [400 N], NVD... US 180 lbf [800 N], NV... US
Position indication	stroke indicator on bracket
Manual override	3/16" hex, 5 mm hex, phillips screwdriver
Running time motor*	150 sec. Independent of load, Independent of stroke
Humidity	5 to 95% RH, non-condensing
Ambient temperature	-22°F to + 122° F [-30°C to 50°C]
Media temperature	20°F to + 250° F [-7°C to 120°C]
Storage temperature	-40°F to +176° F [-40°C to 80°C]
Housing	NEMA 2/ IP54 with cable entry down
Housing material	UL 94-5V (flammability rating)
Agency listing	CE, UL 873, CSA C22.2 NO.24 certified
Quality standard	ISO 9001
Noise level	max. 35 dB(A)
Servicing	maintenance free
Weight	4 lb [1.8 kg]

* Variable

Dimensions in inches (numbers in brackets are metric)

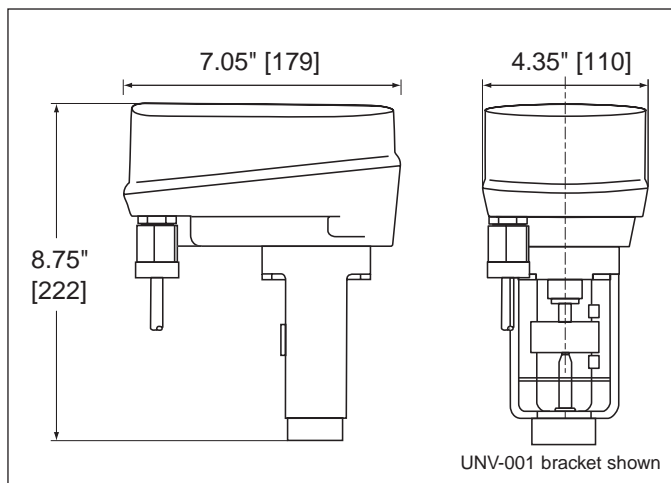

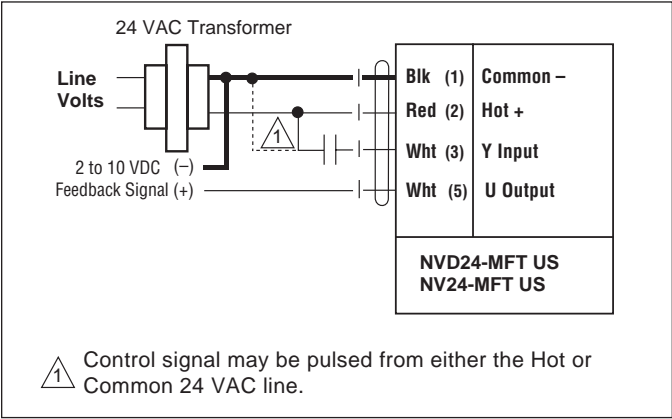

Pulse width modulation control wiring

Range Available: 20 ms to 50 sec.

Typical:

0.59 to 2.93	V-20001
0.02 to 5.00	V-20002
0.10 to 25.5	V-20003
Custom configurations available	

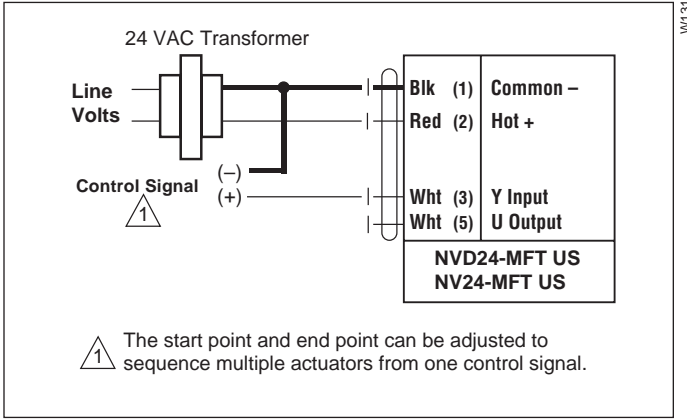

Start point and stop adjustable wiring

Range Available: Start 0.5 to 30 VDC
Stop 2.5 to 32 VDC

Typical:

2 - 10 VDC	V-10001
0 - 10 VDC	V-10002
4 - 7 VDC	V-10004
6 - 9 VDC	V-10005
Custom configurations available	

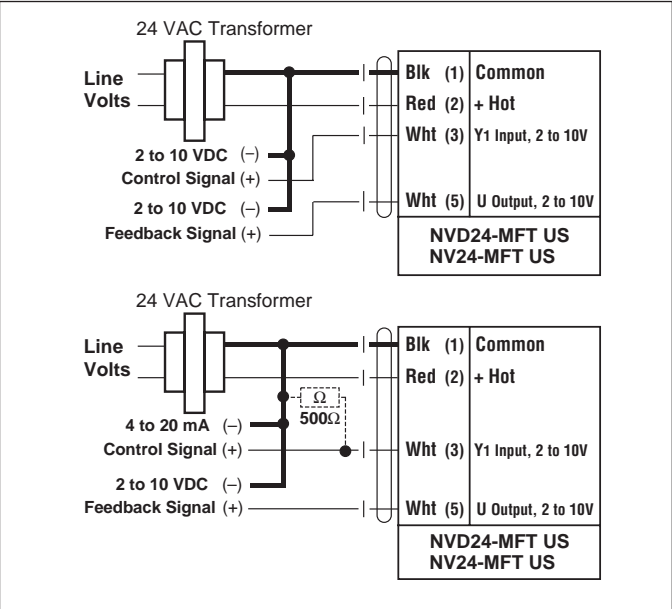

MFT typical 2 to 10 VDC or 4 to 20 mA wiring

Electronic Globe Valves

NV(D)24-3 US Non-spring return, on/off, floating point



NV24-3 US NVD24-3 US

Application

For on/off and floating point control of globe valves. Actuator will mate to an integrated adaptor bracket. Adaptor bracket shown fits valves manufactured by Siebe Environmental Controls under designations VB7000 and VB9000.

Functional safety

The actuator is secured against short circuiting and incorrect polarity.

Manual operation

When a 3/16" or 5 mm hex is inserted and turned clockwise, the actuator plunger pushes out. The actuator plunger retains the position until the nominal voltage is applied.

Display of function

The stroke is shown mechanically on the adaptor bracket.

On/Off, Floating Point Control, 24 VAC/DC Power

NV24-3 US, NVD24-3 US

Power consumption:	3W
Transformer sizing:	5 VA (Class 2 power source)
Force:	<input type="checkbox"/> NV24-3 US: 180 lbf [800N] <input type="checkbox"/> NVD24-3 US: 90 lbf [400N]

Common Data

Power supply:	24 VAC \pm 20% 50/60 Hz 24 VDC \pm 10%
Electrical connection:	3 ft, 18 GA appliance cable, 1/2" conduit fitting
Overload protection:	electronic throughout stroke
Maximum stroke:	3/4" [20 mm]
Position indication:	stroke indicator on bracket
Manual override:	3/16" hex, 5mm hex, phillips head screwdriver
Running time:	50s/0.25" [7.5s/mm]
Humidity:	5 to 95% RH, non-condensing
Ambient temperature:	-22° F to 122° F [-30° C to 50° C]
Media temperature:	20° F to 250° F [-7° C to 120° C]
Storage temperature:	-40° F to 176° F [-40° C to 80° C]
Housing:	NEMA 2 / IP54 with cable entry down
Housing material:	UL 94-5V (flammability rating)
Agency listings:	CE, UL 873, CSA C22.2 No. 24 certified
Quality standard:	ISO 9001
Noise level:	max. 35 dB(A)
Servicing:	maintenance free
Weight:	3.3 lb [1.5 kg]

Dimensions in inches (numbers in brackets are metric)

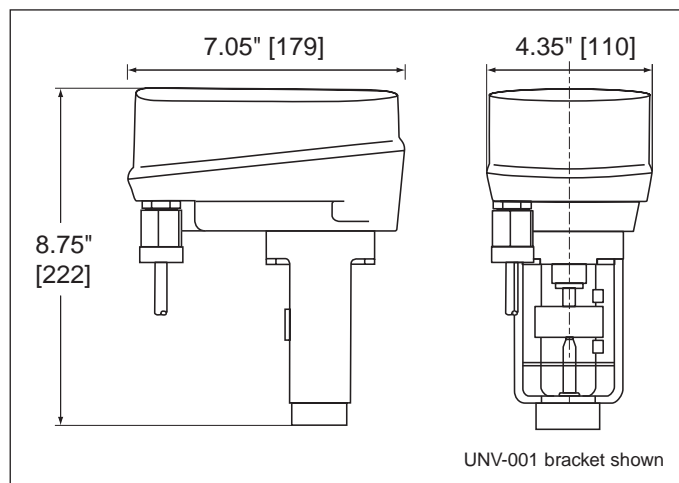

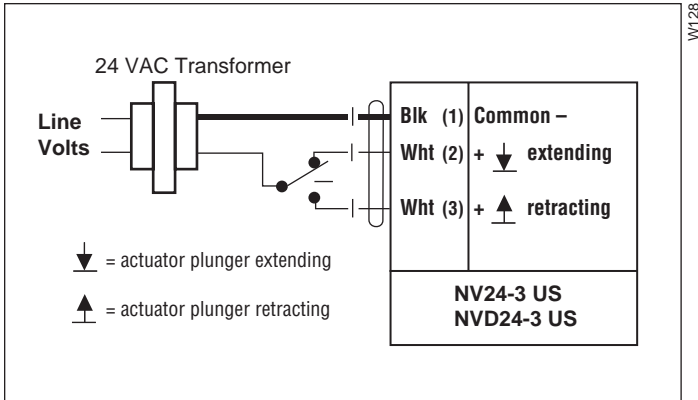

Floating point or on/off control

Electronic Globe Valves

NVF... Series Spring return fail safe, direct coupled globe valve actuator, on/off, floating point, proportional control



Technical Data	NVF... Series
Power Supply:	24 VAC +/- 20% 50/60 Hz 24 VDC +/- 10%
Power consumption	5.5 W
Transformer sizing	10 VA (Class 2 power supply)
Electrical connection	3 ft, 18 GA appliance cable, 1/2" conduit fitting
Overload protection	electronic throughout stroke
Control signal Y*	2 to 10 VDC, NVF...MFT(-E) US, V-10001 Default Pulse width modulation, NVF...MFT(-E) US V-20... (selectable when ordered) Floating point, NVF...MFT(-E) US, V-30001 Default (when ordered) On-Off, NVF...(-E) US, V-40002 Default (when ordered)
Operating range*	2 to 10 VDC, 4 to 20 mA (w/500Ω, 1/4 W resistor), NVF...MFT(-E) US
Input impedance	100KΩ for 2 to 10 VDC, 500W for 4 to 20 mA 750Ω for PWM 1500Ω for On-Off, Floating point
Feedback*	2 to 10VDC, 0.5 mA max., NVF...MFT (-E) US
Maximum stroke	3/4" [20 mm]
Plunger	NVF... US, Spring UP NVF...-E US, Spring DOWN
Force	90 lbf [400 N], NVFD... (-E) US 180 lbf [800 N], NVF... (-E) US
Position indicator	stroke indicator on bracket
Manual override	3/16" hex, 5 mm hex, phillips screwdriver
Running time motor*	150 sec. Independent of load and Independent of stroke
Running time spring	30 sec. at 3/4" [20 mm] stroke
Humidity	5 to 95% RH, non-condensing
Ambient temperature	-22°F to + 122° F [-30°C to 50°C]
Media temperature	20°F to + 250° F [-7°C to 120°C]
Storage temperature	-40°F to +176° F [-40°C to 80°C]
Housing	NEMA 2/ IP54 with cable entry down
Housing material	UL 94-5V (flammability rating)
Agency listing	CE, UL 873, CSA C22.2 NO.24 certified
Quality standard	ISO 9001
Noise level	max. 35 dB(A)
Servicing	maintenance free
Weight	4 lb [1.8 kg]

* Variable

NVFD24 US
NVFD24-E US
NVFD24-MFT US
NVFD24-MFT-E US
NVF24-MFT US
NVF24-MFT-E US

Application

For on/off, floating point and proportional control of globe valves. Actuator will mate to an integrated adaptor bracket. Adaptor bracket shown fits valves manufactured by Siebe Environmental Controls (Invensys) under designations VB7000 and VB9000.

Functional safety

The actuator is secure against short circuiting and incorrect polarity. The stroke is adapted automatically and is overload-protected. The spring return function in the actuator is pre-tensioned when delivered. Pressing a 3/16" or 5 mm hex into the housing cover releases the spring stop.

Manual operation

When a 3/16" or 5 mm hex is inserted, depressed and turned clockwise, the actuator plunger pushes out. The actuator plunger retains the position until the nominal voltage is applied.

Display of function

The stroke is shown mechanically on the adaptor bracket, and the maximum stroke is set automatically. Under the housing cover on -MFT models is a two-colored LED display which will verify that the actuator is set up properly.

Multi-Function Technology® (MFT)

An integrated microprocessor allows for a great variety of parameters to be easily configured at the factory or in the field.

Dimensions in inches (numbers in brackets are metric)

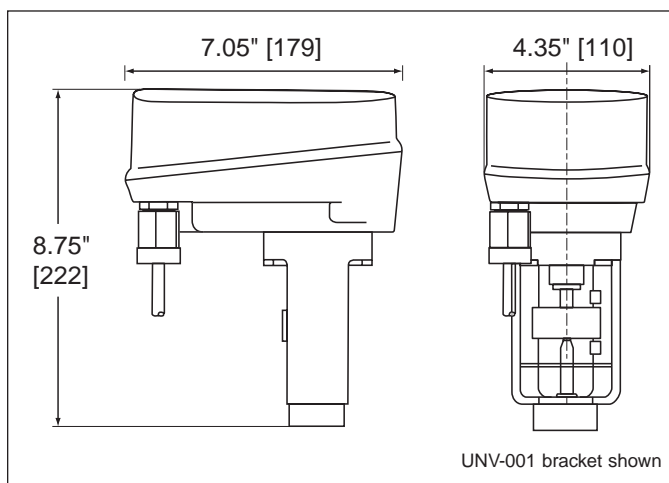

D030

E20222 5 4 3 2 1 05/02-10M-EG-Subject to change. © Belimo Aircontrols (USA), Inc.

NVF... Series Spring return fail safe, direct coupled globe valve actuator, on/off, floating point, proportional control

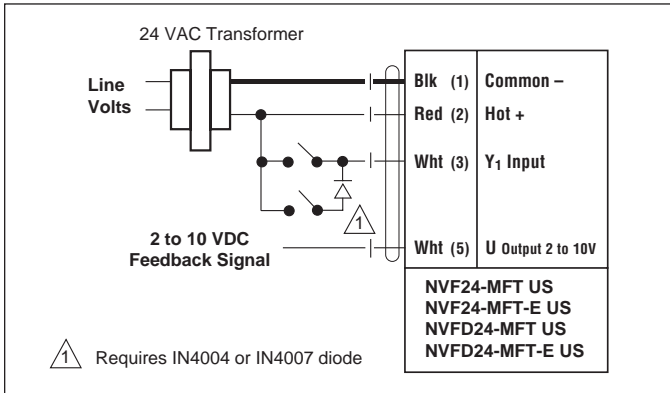

Floating point control: P-30... configurations

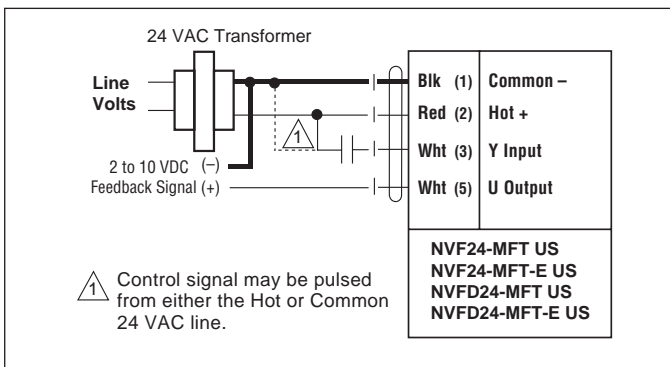

Pulse width modulation control wiring

Range Available: 20 ms to 50 sec.

Typical:	0.59 to 2.93	V-20001
	0.02 to 5.00	V-20002
	0.10 to 25.5	V-20003
Custom configurations available		

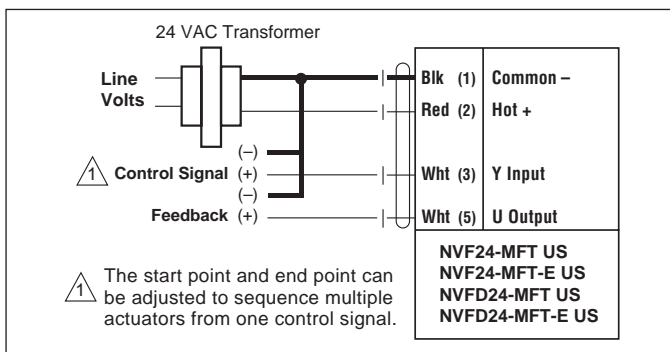

Start point and stop adjustable wiring

Range Available: Start 0.5 to 30 VDC
Stop 2.5 to 32 VDC

Typical:	2 - 10 VDC	V-10001
	0 - 10 VDC	V-10002
	4 - 7 VDC	V-10004
	6 - 9 VDC	V-10005
Custom configurations available		

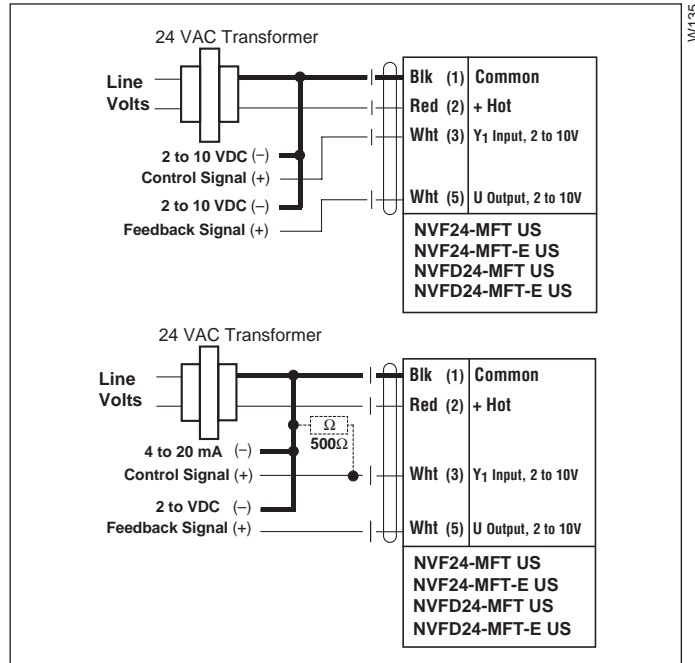

MFT typical 2 to 10 VDC or 4 to 20 mA wiring

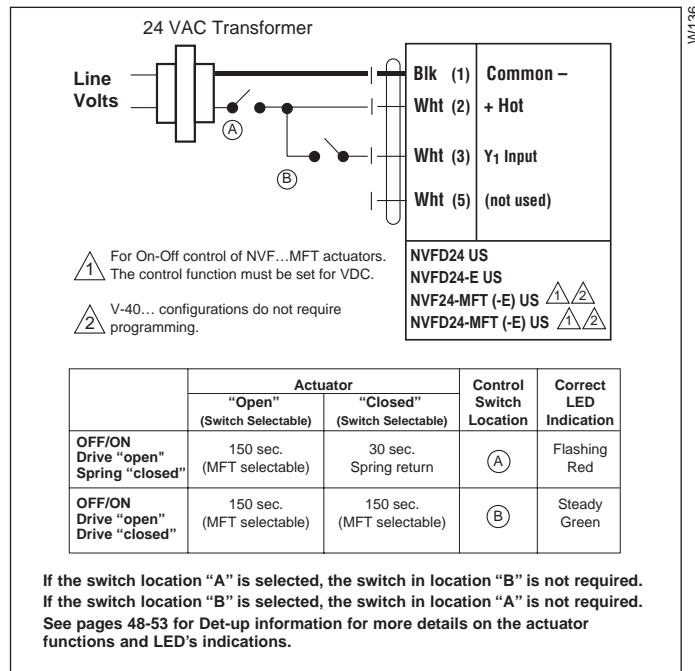

On/off control

Spring return actuators model designation

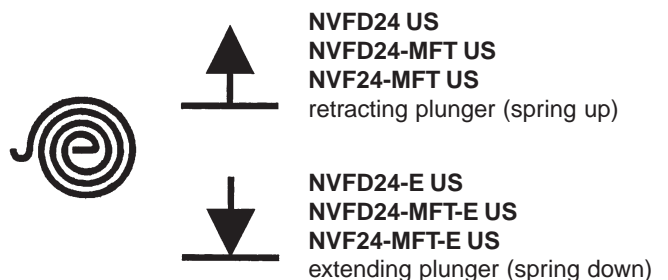

Electronic Globe Valves

G2 Series Globe Valve With NV... or NVF... Actuators



G2 Series Two-Way

Application

G2 Series two-way valves control water or steam for 2-position or modulating control applications. Valves conform to ANSI class 250 rating for screwed cast bronze bodies.

Actuators

A number of combinations are possible. Both spring return (NVF...) and non-spring return actuators (NV...) are available.

Piping

The valve should be mounted in a weather-protected area in a location that is within the ambient limits of the actuator. Allow sufficient room for valve with actuator and for service. Allow 6" for cover removal and 12" for complete actuator removal. The assembly can be mounted with the actuator vertical or horizontal in relation to the pipe. G2 series two-way "A" port is inlet, "AB" port is outlet (Do not reverse flow direction).

WARNING

These valves are not for combustible gas applications as leaks and explosions could result.

Specifications

Service	chilled or hot water, 60% glycol, steam		
Flow Characteristic	equal percentage		
Action	Stem up open A to AB		
Sizes	1/2" to 2"		
Type of End Fitting	NPT		
Materials:			
Body	bronze		
Seat	bronze		
Stem	stainless steel		
Plug	brass		
Packing	spring loaded TFE		
Disc	Composition (EPDM)		
ANSI Class	250 (up to 400 psi below 150°F)		
Leakage	ANSI Class IV		
Maximum Inlet Pressure Steam	15 psi [103 kPa]		
Ambient temp. range	-22°F to 122°F [-30°C to 50°C]		
Media Temp. Range	20°F to 250°F [-7°C to 120°C]		
Maximum Differential Pressure	water 35 psi [241 kPa] steam 15 psi [103 kPa]		
Rangeability	G212 5:1	G219 50:1	
	G213 15:1	G220 60:1	
	G214 25:1	G224 60:1	
	G215 40:1	All others 75:1	

Assembly Dimensions in inches

(numbers in brackets are metric)

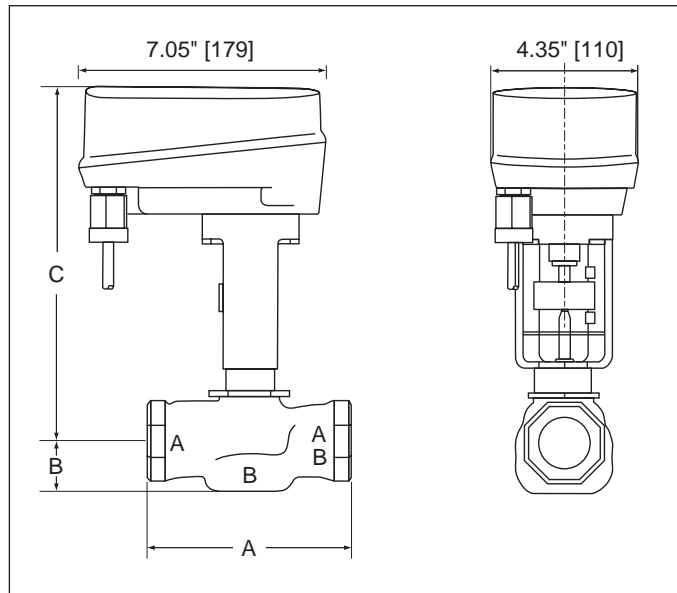

2-Way

Pipe Size	A	B	C
1/2" [15]	3-1/16" [78]	1-1/16" [27]	9-3/4" [248]
3/4" [20]	3-5/8" [92]	1-1/16" [27]	9-3/4" [248]
1" (25)	4-5/8" [117]	1-1/8" [29]	10-7/16" [265]
1-1/4" (32)	4-5/8" [117]	1-3/8" [35]	10-7/16" [265]
1-1/2" (40)	5-3/8" [137]	1-1/2" [38]	10-1/2" [267]
2" (50)	6-1/8" [156]	1-9/16" [40]	10-13/16" [275]

Assembly uses UNV-001 Bracket



G2...S Series Two-Way

Application

G2...S Series two-way valves control water or steam up to 50 psi inlet, for 2-position or modulating control applications. Valves conform to ANSI class 250 rating for screwed cast bronze bodies.

Actuators

A number of combinations are possible. Both spring return (NVF...) and non-spring return actuators (NV...) are available.

Piping

The valve should be mounted in a weather-protected area in a location that is within the ambient limits of the actuator. Allow sufficient room for valve with actuator and for service. Allow 6" for cover removal and 12" for complete actuator removal. The assembly can be mounted with the actuator vertical or horizontal in relation to the pipe. G2...S series two-way "A" port is inlet, "AB" port is outlet (Do not reverse flow direction).

Warning

These valves are not for combustible gas applications as leaks and explosions could result.

Specifications

Service	Chilled or Hot Water, 60% glycol steam
Flow Characteristic	Linear
Action	Stem up open A to AB
Sizes	1/2" to 2"
Type of End Fitting	NPT
Materials:	
Body	Bronze
Seat	Stainless Steel
Stem	Stainless Steel
Plug	Stainless Steel
Packing	Spring Loaded TFE
Disc	Teflon
ANSI Class	250 (up to 400 psig below 150°)
Leakage	ANSI IV Close-off
Maximum Inlet Pressure Steam	50 psi (345kPa)
Ambient temp. range	-22°F to 122°F (-30°C to 50°C)
Media Temp. Range	20° F to 300° F (- 7 °C to 149 °C)
Maximum Differential Pressure	Water 35 psi [241 kPa] Steam 35 psi [241 kPa]
Rangeability	G212S 5:1 G219S 50:1 G213S 15:1 G220S 60:1 G214S 25:1 G224S 60:1 G215S 40:1 All others 75:1

Dimensions in inches (All ratings in brackets are metric)

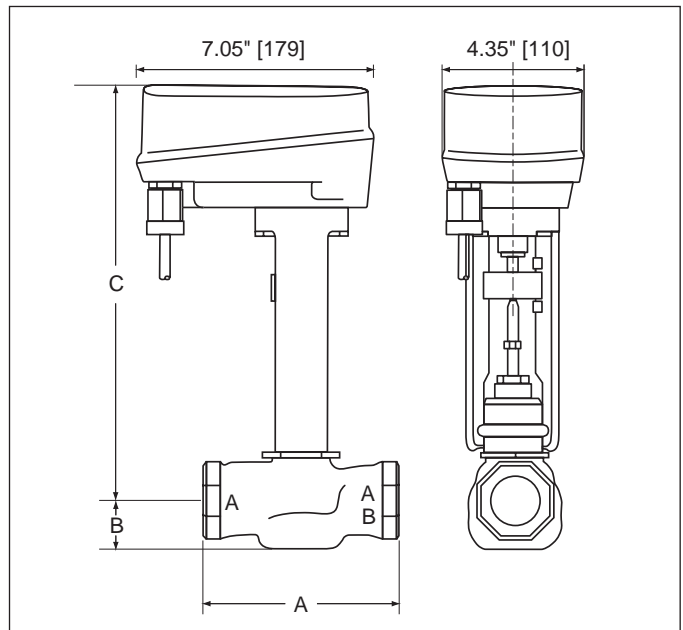

2-way

Pipe Size	A	B	C
1/2" [15]	3-1/16" [78]	1-1/16" [27]	11-5/16" [287]
3/4" [20]	3-5/8" [92]	1-1/16" [27]	11-5/16" [287]
1" [25]	4-5/8" [117]	1-1/8" [29]	12-0" [305]
1-1/4" [32]	4-5/8" [117]	1-3/8" [35]	12-0" [305]
1-1/2" [40]	5-3/8" [137]	1-1/2" [38]	12-1/16" [306]
2" [50]	6-1/8" [156]	1-9/16" [40]	12-3/8" [314]

UNV-035 used. Bracket is 1-9/16" longer than the UNV-001

Electronic Globe Valves



G3 and G3...D Series Globe Valve With NV... or NVF... Actuators



G3 Series Three-Way (mixing) G3...D Series Three-Way (diverting)

Application

G3 Series three-way mixing valves and G3...D diverting valves control water for two position or modulating control applications. Call Belimo for diverting applications. Valves conform to ANSI class 250 rating for screwed cast bronze bodies.

Actuators

A number of combinations are possible. Both spring return (NVF...) and non-spring return actuators (NV...) are available.

Piping

The valve should be mounted in a weather-protected area in a location that is within the ambient limits of the actuator. Allow sufficient room for valve with actuator and for service. Allow 6" for cover removal and 12" for complete actuator removal. The assembly can be mounted with the actuator vertical or horizontal in relation to the pipe. G3 series three-way: "A" port is inlet, "B" port is bypass, "AB" port is outlet. G3...D series three-way: "B" port is inlet "Flow" arrow is outlet "AB" port is outlet (Do not reverse flow direction).

WARNING

These valves are not for combustible gas applications as leaks and explosions could result.

Specifications

Service	chilled or hot water, 60% glycol
Flow Characteristic	linear - mixing only
Action	3-way Diverting: stem up closes B to flow arrow/opens B to AB stem down closes B to AB/opens B to flow arrow 3-way Mixing: stem up closes A to AB/opens B to AB stem down closes B to AB/opens A to AB
Sizes	1/2" to 2"
Type of End Fitting	NPT
Materials:	
Body	bronze
Seat	bronze
Stem	stainless steel
Plug	brass
Packing	spring loaded TFE
Disc	None
ANSI Class	250 (up to 400 psi below 150°F)
Leakage	ANSI Class III
Ambient temp. range	-22°F to 122°F (-30°C to 50°C)
Media Temp. Range	20°F to 250°F [-7°C to 120°C]
Maximum Differential Pressure	water 35 psi [241 kPa]
Rangeability	500:1 (based on Class III leakage).

Assembly Dimensions in inches

(numbers in brackets are metric)

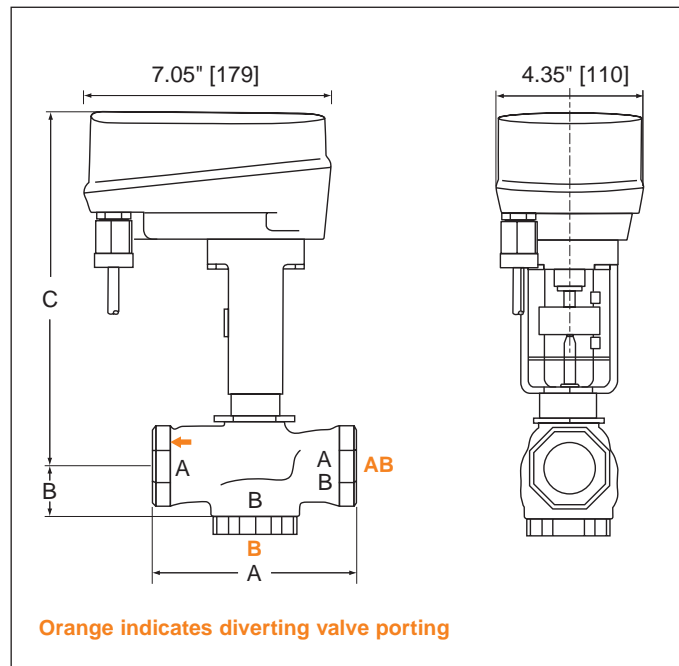

3-Way

Pipe Size	A	B	C
1/2" [15]	3-1/16" [78]	1-3/8" [35]	9-3/4" [248]
3/4" [20]	3-5/8" [92]	1-11/16" [43]	9-3/4" [248]
1" [25]	4-5/8" [117]	1-9/16" [40]	9-13/16" [249]
1-1/4" [32]	4-5/8" [117]	1-5/8" [41]	10-1/16" [256]
1-1/2" [40]	5-3/8" [137]	1-5/8" [41]	9-3/16" [234]
2" [50]	6-1/8" [156]	1-7/8" [48]	9-1/4" [235]

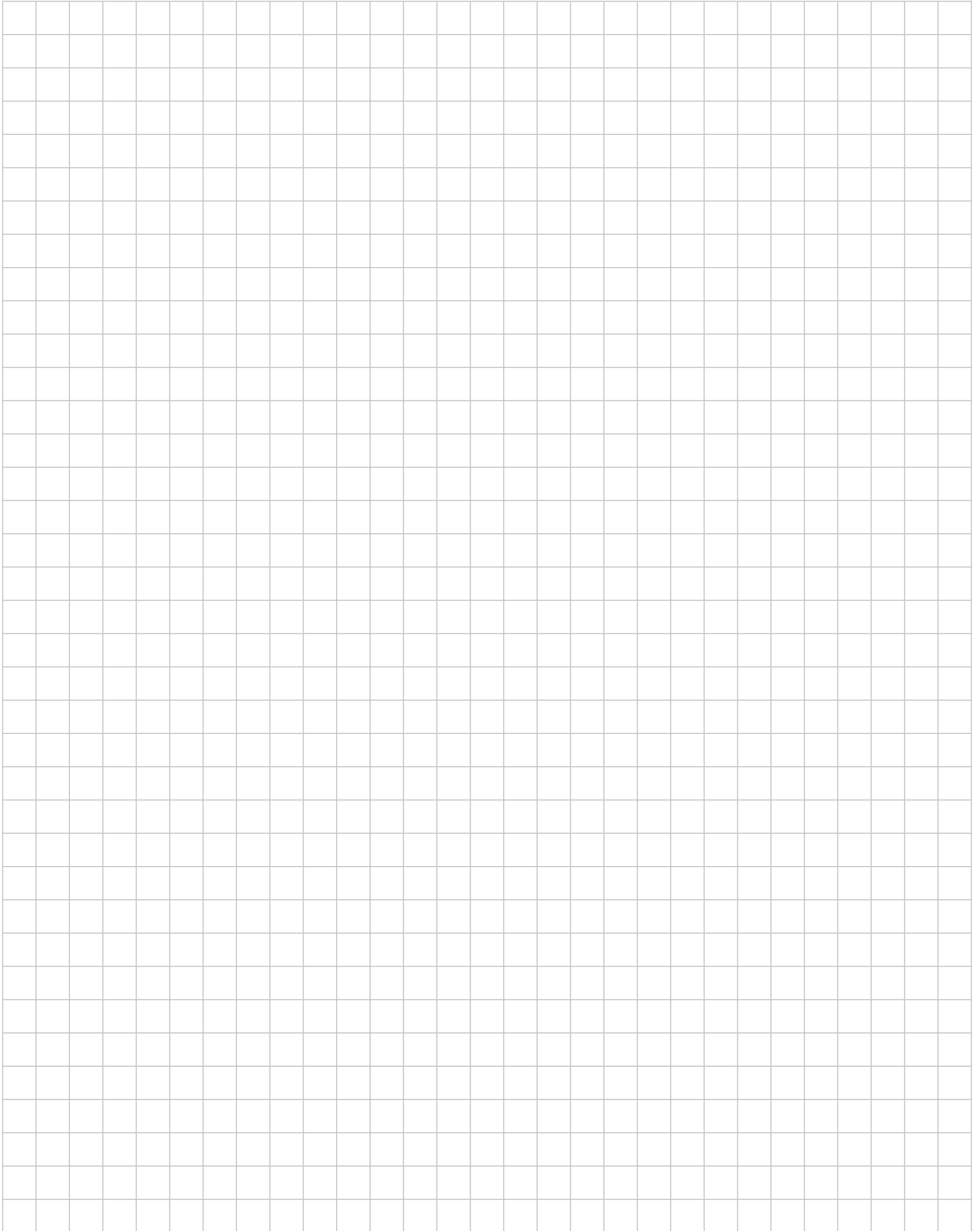

Operation/Installation

Flow Pattern/Assembly:

G2 Two-way

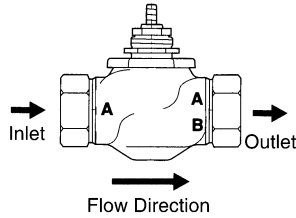

G3 Three-way Mixing

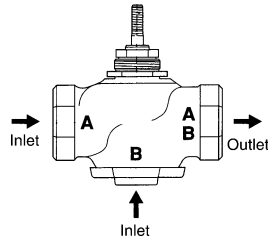

G3...D Three-way Diverting

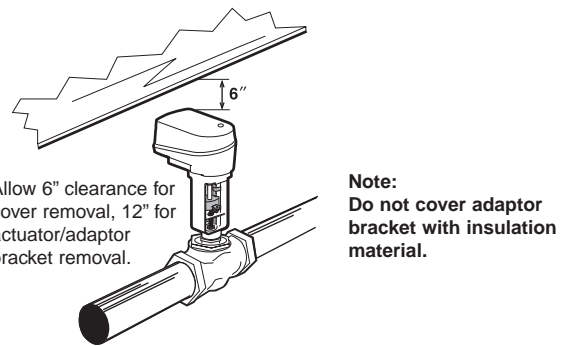
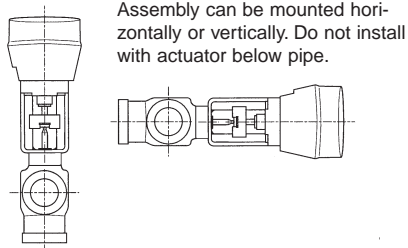
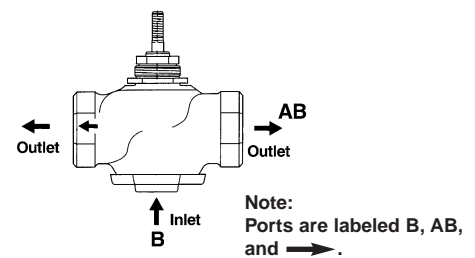

Piping:

Two-Way Valve Piping Diagram (1 Input, 1 Output)

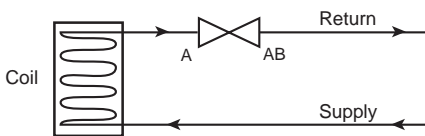

Three-Way Mixing Valve Piping Diagram (2 Inputs, 1 Output)

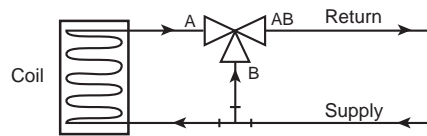

Three-Way Diverting Valve Piping Diagram (1 Input, 2 Outputs)

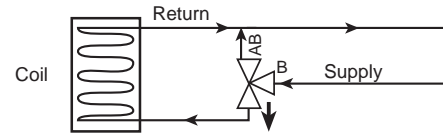

Operation/Installation

Default Set-Up:

Set-Up - 2-way valves - Factory Defaults and Custom Set-ups.

Valves will be shipped with the default set-up unless custom set-up is specified upon ordering.

SPRING RETURN ACTUATOR	SPRING ACTION	DEFAULT (2-way)	CUSTOM (2-way)
NVF24-MFT US NVFD24-MFT US	Spring Up Spring Up	NC = Normally Closed A to AB FO = Fail Open A to AB	NO = Normally Open A to AB FO = Fail Open A to AB
NVF24-MFT-E US NVFD24-MFT-E US	Spring Down Spring Down	NC = Normally Closed A to AB FC = Fail Closed A to AB	NO = Normally Open A to AB FC = Fail Closed A to AB

Note: All valves are set-up closed A to AB at 2V. Increase in voltage/power will open valve A to AB. NO/NC action can be changed using S3 switch in MFT actuator.

Set-Up - 3-way valves - Factory Defaults and Custom Set-ups.

Valves will be shipped with the default set-up unless custom set-up is specified upon ordering.

SPRING RETURN ACTUATOR	SPRING ACTION	DEFAULT (3-way)	CUSTOM (3-way)
NVF24-MFT US NVFD24-MFT US	Spring Up Spring Up	NC = Normally Closed A to AB FC = Fail Closed A to AB	NO = Normally Open A to AB FC = Fail Closed A to AB
NVF24-MFT-E US NVFD24-MFT-E US	Spring Down Spring Down	NC = Normally Closed A to AB FO = Fail Open A to AB	NO = Normally Open A to AB FO = Fail Open A to AB

Note: All valves are set-up closed A to AB at 2V. Diverting valves will be set up B to ➔ closed, B to AB open at 2V. Increase in voltage/power will open valve A to AB. NO/NC action can be changed using S3 switch in MFT actuator.

Set-Up - 2-way and 3-way valves - Factory Defaults and Custom Set-ups.

Valves will be shipped with the default set-up unless custom set-up is specified upon ordering.

NON-SPRING RETURN ACTUATOR	DEFAULT (2-way and 3-way)	CUSTOM (2-way and 3-way)
NV(D)24-3 US NV(D)24-MFT US	NC = Normally Closed NC = Normally Closed	NO = Normally Open NO = Normally Open

Note: Non-Spring Return Actuator will fail in last position upon loss of power. All valves are set-up closed A to AB at 2V. Increase in voltage/power will open valve A to AB. **NO/NC** action can be changed using S3 switch in MFT actuator, or can be specified at time of order.

Operation/Installation UNV-001 Series

Installation instructions for Siebe VB7000 and VB9000 series valves.

1. Remove all existing linkage and push stem to down position.
2. Screw lock nut (L) and stem adaptor (I) onto valve stem.
3. With stem pushed down completely adjust stem adaptor (I) height for corresponding valve. Tighten lock nut (L). (See Fig. 1).
4. Attach bracket (E) onto bottom of NV actuator (A) with 4 provided screws (B).
5. Press locking mechanism (C) into valve coupling (D). (See Fig.3).
6. Attach Valve Coupling (D) to actuator plunger (K). (See Fig. 3). Note: valve coupling must be centered and level within bracket frame (See Figure 2).
7. Attach stroke indicators (G) above and below the Valve coupling.
8. Screw NV actuator (A) onto valve, and tighten valve bonnet nut (J).
9. Press locking mechanism (C) into valve coupling (D). Locking pin (F) must not be engaged (See Fig. 3).
10. Lower plunger (K) using manual override until stem adaptor (I) meets valve coupling. When connected, locking mechanism (C) pops out of valve coupling.
11. Secure by pressing locking pin (F) up into locking mechanism.
12. Move sliding stroke indicators (G) to sit above and below lip on valve coupling (H). Stroke indicators are automatically repositioned to the maximum stroke when power is applied to actuator.
13. Set actuator switches S3.1, S3.2 to desired settings (See attached data).

When disassembling, the locking pin (F) must first be withdrawn from the locking mechanism. The locking mechanism is then pressed into the valve coupling, and the valve stem will disengage when plunger (E) is raised.

Recommended installation location

It is permissible to install the NV actuator upright or horizontally. However, it is not recommended that the valve stem be installed facing downward. Allow 12 inches of clearance for removal of actuator and 6 inches for removal of actuator cover.

No special tools are needed for the installation. Corresponding installation instructions are packaged with the NV actuator and valve.

Initial start-up

The unit must not be started up until the valve and actuator have been assembled according to instructions. Adaptation (initialization) will only occur the first time the actuator is powered. To reset, remove housing cover and press adaptation button S2. (See attached set-up information).

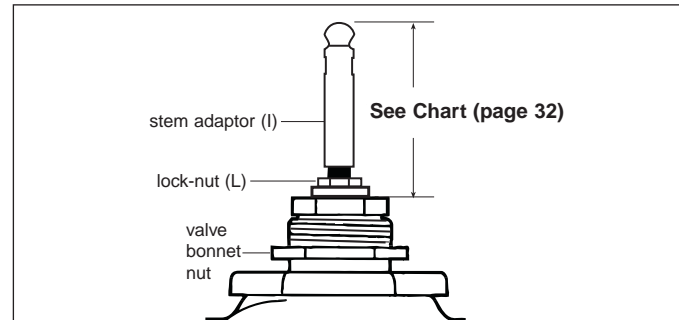

Fig. 1

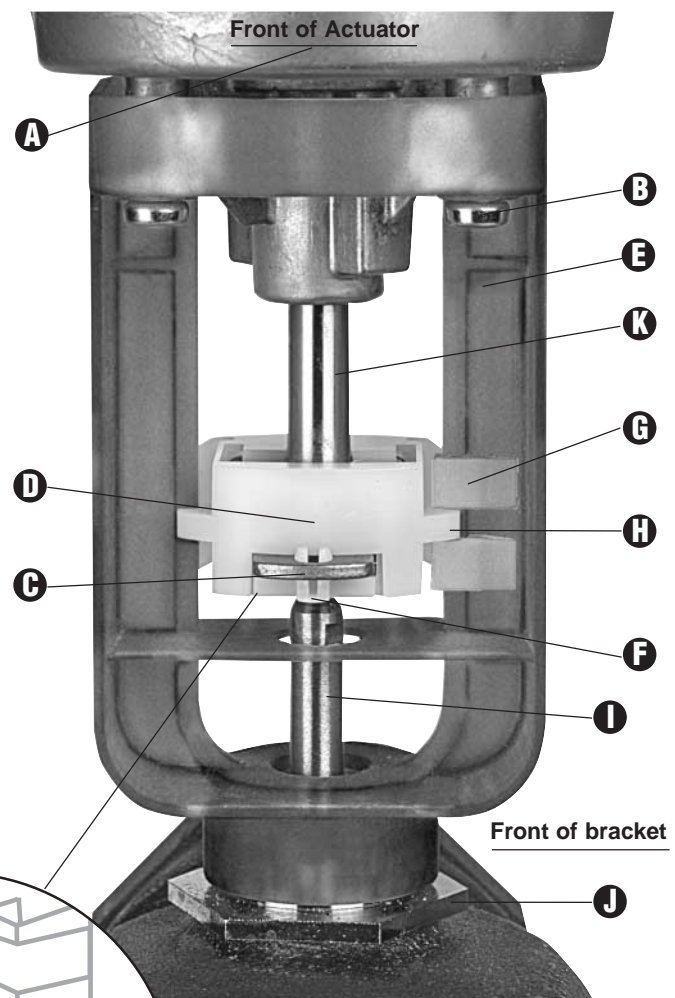

Fig. 2

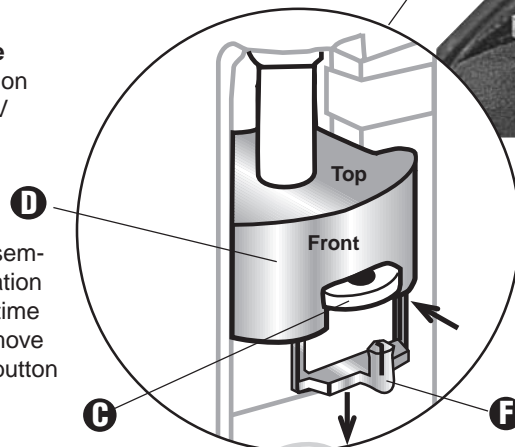

Fig. 3

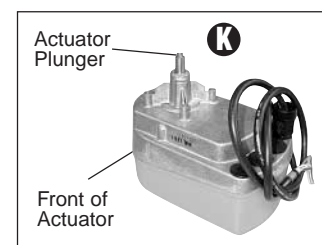

Fig. 4

Operation/Installation UNV-003 to UNV-035 Series

Installation instructions for UNV-003 to UNV-035 Series

1. Remove all existing linkage and push valve stem to its furthest down position.
2. Attach bracket (E) onto bottom of NV actuator (A) with 4 provided screws (B).
3. Press locking mechanism (C) into valve coupling (D). (See Fig.3).
4. Attach valve coupling (D) to actuator plunger (K). (See Fig. 3). Note: valve coupling must be centered and level within bracket frame, see Figure 2. (Note bracket configuration)
5. Attach stroke indicators (G) above and below the valve coupling.
6. Screw collar (J) onto valve neck. Tighten set screws if present. The flats should be on the bottom of the collar. (Note collar mounting position Fig.1.)
7. Screw Lock-nut (N) and Stem adaptor (I) onto the valve stem (Kit UNV-003 needs no stem height adjustment. Use assembly instructions for UNV-003 noted below:
 - Pull existing stem adaptor all the way up.
 - Place stem compression fitting (1) onto existing stem adaptor.
 - Place UNV-003 stem adaptor into flanged nut (2).
 - Pull UNV-003 stem adaptor upward as you screw and tighten the flanged nut (2) onto the stem compression fitting. (See inset Fig.1.) Use Chart (page 32) to determine the height of the stem adaptor for UNV-004 through UNV-035.
8. Tighten lock-nut (N) to base of stem adaptor.
9. Mount bracket by placing U bolt (L) through the bracket and tighten the screws using a 10mm wrench. NOTE: the U bolt should fit in the track provided in the collar.
10. Press locking mechanism (C) into valve coupling (D). Locking pin (F) must not be engaged. (See Fig.2).
11. Lower plunger (K) using manual override until stem adaptor (I) meets valve coupling. When connected, locking mechanism (C) pops out of valve coupling.
12. Move sliding indicators (G) to sit above and below lip on valve coupling (H). Stroke adaptors will be automatically repositioned to the maximum stroke when power is applied to actuator.
13. Set actuator switches S3.1, S3.2 to desired settings (See attached data).

When disassembling, the locking pin (F) must first be withdrawn from the locking mechanism. The locking mechanism is then pressed into the valve coupling, and the valve stem will disengage when plunger is raised.

Recommended installation location

It is permissible to install the NV actuator upright or horizontally. However, it is not recommended that the valve stem be installed facing downward. Allow 12 inches of clearance for removal of actuator and 6 inches for removal actuator cover.

Initial start-up

The unit must not be started up until the valve and actuator have been assembled according to instructions. Adaptation (initialization) will only occur the first time the actuator is powered. To reset, remove housing cover and press adaptation button S2. (See attached set-up information).

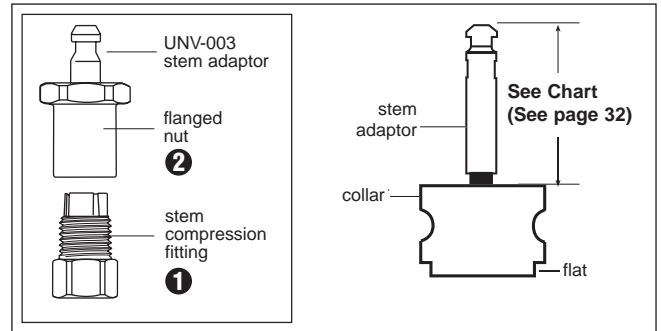

Fig. 1

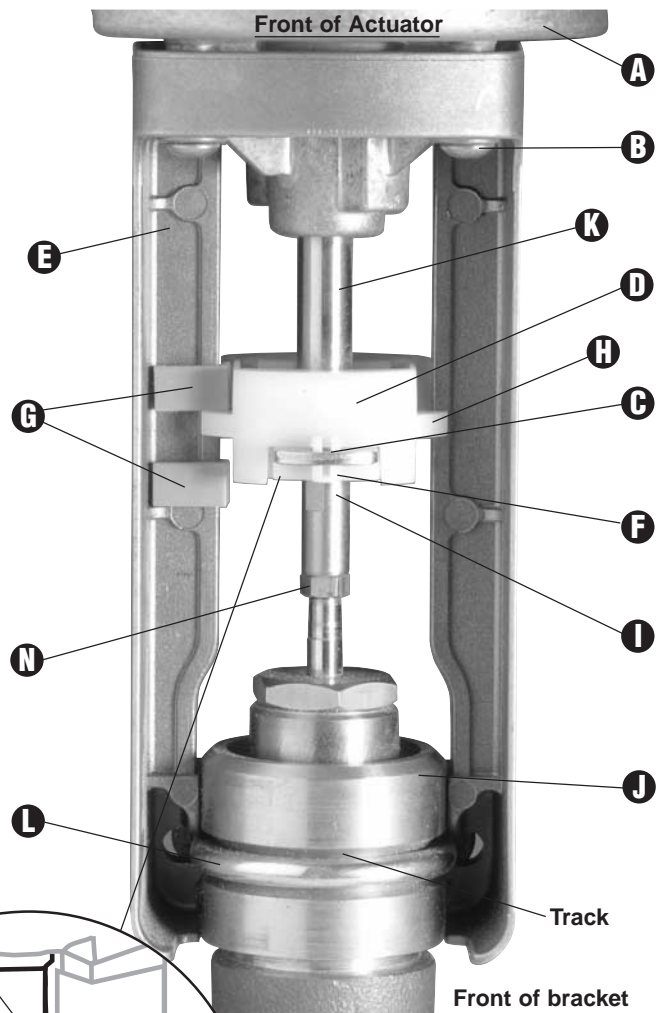

Fig. 2

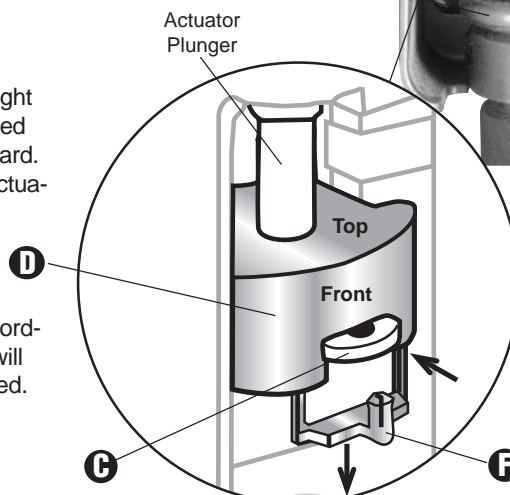

Fig. 3

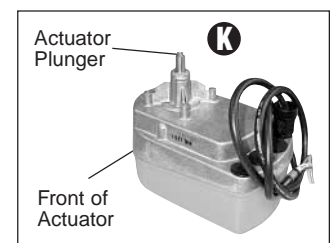

Fig. 4

Operation/Installation

Set-Up of NV24-3 US, NVD24-3 US Actuators during Installation

Beneath the cover of the actuator are the terminals for the cable connection and the S1 switch.

The floating point signal is processed in the microprocessor and conveyed to the motor.

Supply voltage is created by the rectifier.

The stroke direction can be reversed with the switch S1.2 (On/Off is indicated on switch). This defines if the valve closes with the plunger up or down. The direction of the plunger can also be inverted by exchanging the wires Y1 and Y2.

Note: Switch S1.2 must be set based on the valve closing point.

Block diagram: NV24-3 US, NVD24-3 US

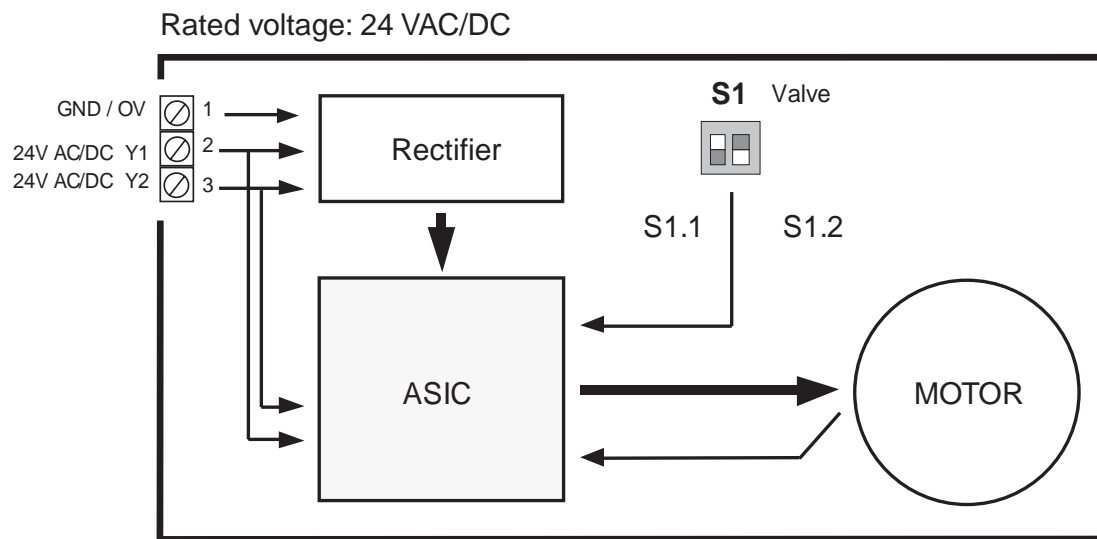

Note: NV24-3 US and NVD24-3 US do not contain test or adaptation functional switches. Adaptation is not necessary for the NV24-3 US and NVD24-3 US actuators.

Functional description

S1	Setting the running times and selecting the valve closing point	
S1.1	Actuating time	
	Off position (Default)	50s/.25" [7.5s/mm]
	On position	Deactivated not used
S1.2	Selecting the closing point	Valve closing point is with the actuator plunger extended or retracted
	Off position	Valve closing point is with the actuator plunger retracted
	On position	Valve closing point is with the actuator plunger extended

Operation/Installation

Set-Up of NV24-3 US, NVD24-3 US Actuators during Installation

**NV24-3 US
NVD24-3 US**

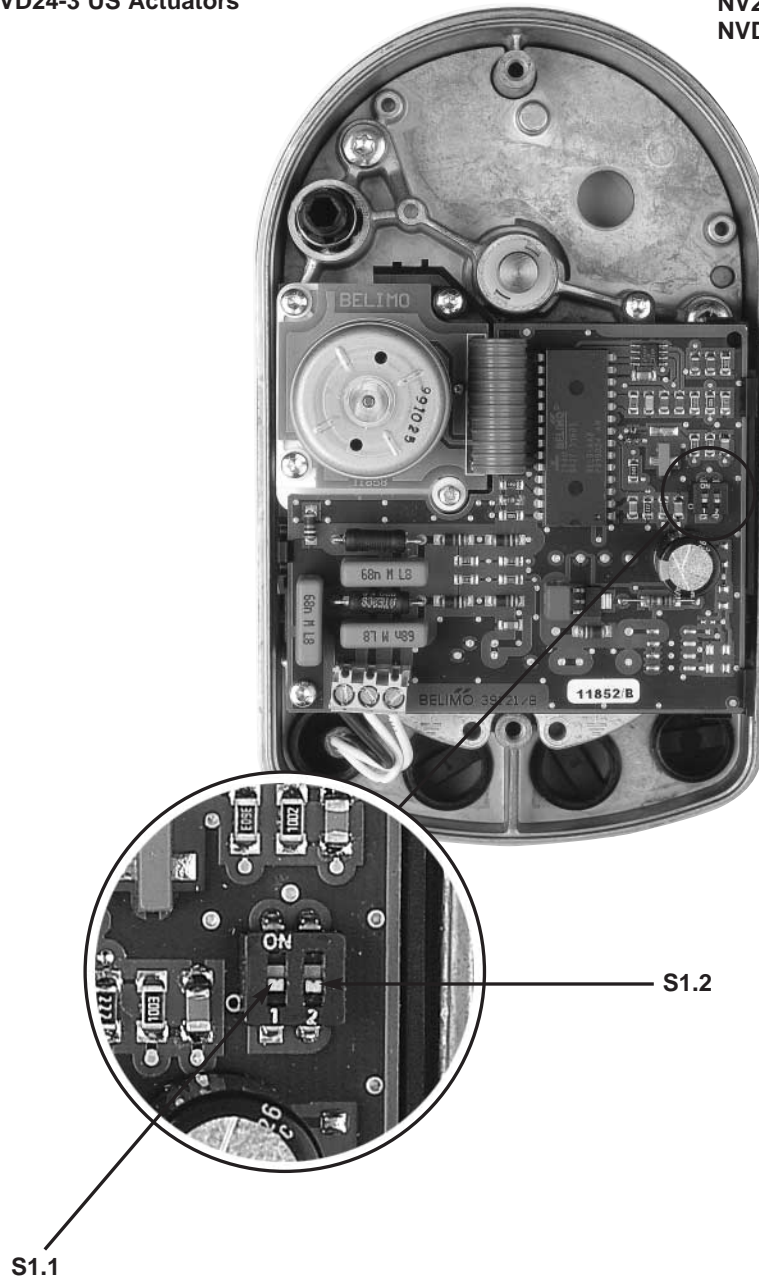

Operation/Installation

Set-Up of NV Series MFT Actuators during Installation

General

Beneath the cover of the actuator are the terminals for the cable connection, the S1 and S2 buttons, S3 switch, and the LED status display H1.

The setting signal is processed in the microprocessor, and conveyed to the motor via drivers. By setting the slide switch S3 or pressing the buttons S1 and S2, the actuator can easily be configured on site to the requirements, if there are changes from the factory settings.

The NV and NVF actuators are maintenance-free. The two-color LED display is located beneath the cover of the actuator. This display allows immediate recognition of the functional state of the actuator. In addition, it permits simple set-up if the factory settings need to be changed.

Block diagram: MFT and Spring Return Actuators

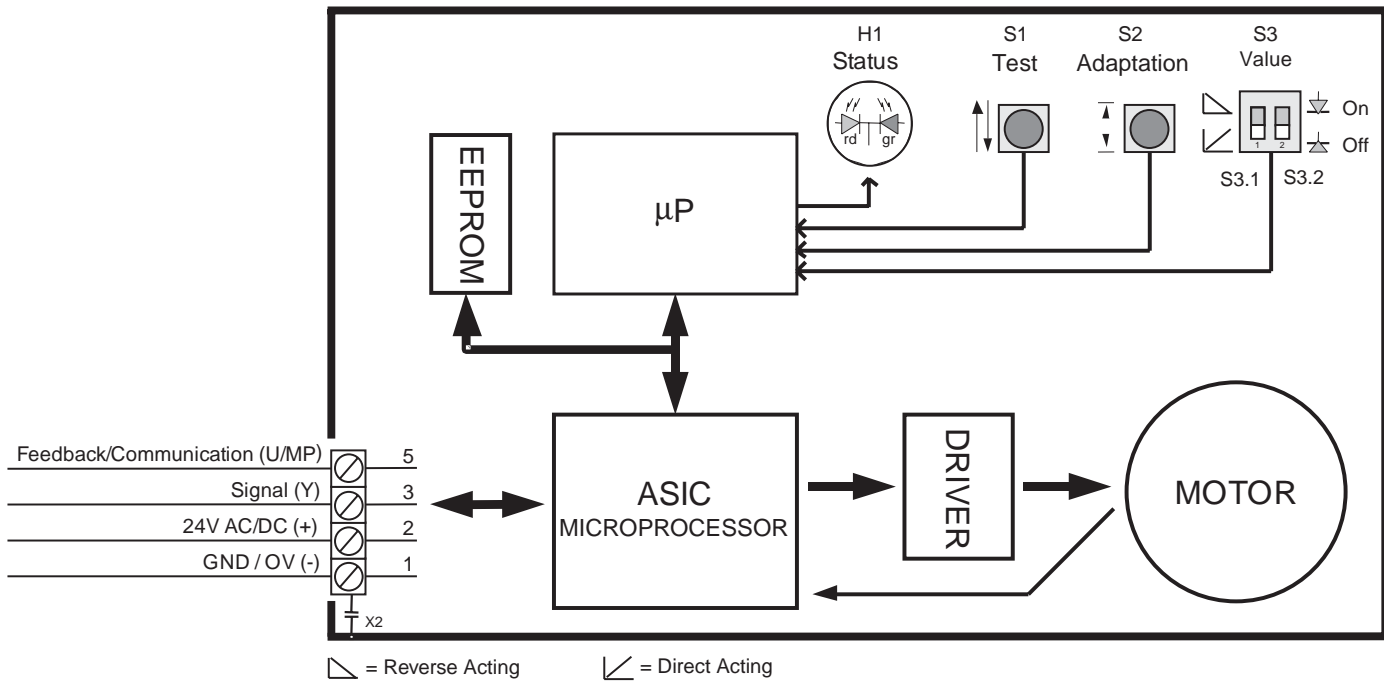

Operation of Switches/LED

LED operating display H1

Green steady light	Actuator working properly
Green flashing light	Test run or adaptation with synchronization in progress
Red steady light	Fault; repeat adaptation
Red flashing light	After power interruption (>2 sec.). By the next closing movement the valve will be automatically synchronized in the chosen closing point. The LED indicator will change from a red flashing into green steady light.
Alternating red/green light	Master control system being addressed and operation of the adaptation button S2 in progress

Operation/Installation

NV...MFT US
NVF...MFT US
NVF...US

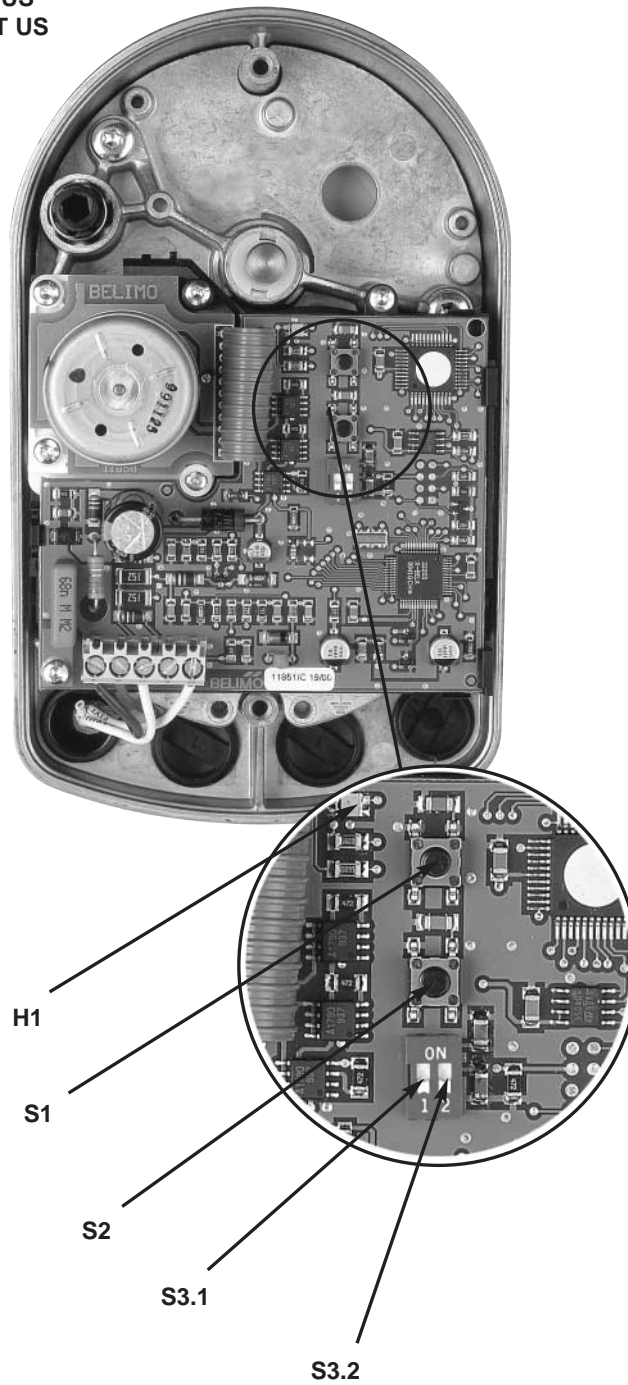

Operation/Installation

Manual Override NV...Non-spring Return

The valve coupling can be adjusted by inserting a 3/16" or 5 mm hex in the housing cover. (Fig. 3).

If the hex is turned clockwise, the coupling moves down; counterclockwise turning moves it up. The manual override is protected against overload. The coupling remains in the manual position as long as the actuator is not connected to the nominal voltage. With the nominal voltage applied to the actuator, the coupling follows the positioning signal.

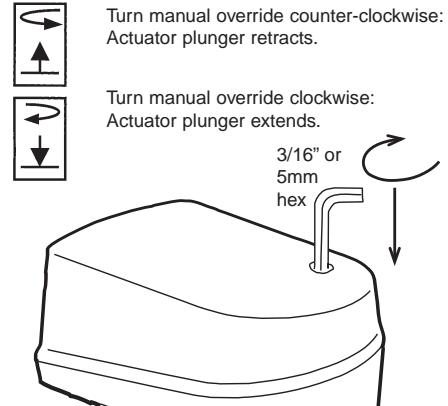

Fig. 3

Over-torquing manual override will not damage actuator.

Manual Override NVF...Spring Return

The valve coupling can be adjusted by inserting a 3/16" or 5 mm hex in the housing cover. (Fig. 3).

The spring return function in the actuator is pre-tensioned when delivered. The manual operating mechanism is overload-proof. The plunger will remain at the manual setting until the power supply to the actuator is turned on or, the next time the power supply is interrupted, it moves to whichever end position has been selected.

NOTE:

1. Do not override the NVF while power is applied to the actuator.
2. If the actuator is overridden while power is applied, remove cover and perform manual adaptation function by pressing S2 button.
3. When overriding the actuator turn the hex 3/4 turn and then press down to lock after the desired position is found. This prevents the gear from over-tightening into an end-position which would prevent the override mechanism from unlocking automatically during power up. If the manual override does not unlock automatically during power-up you must unlock the actuator manually with the hex.
4. Use the NV... MFT in only closed control loops.

NVF... Retracting, Spring Up

① Disengaging manual operation

Turn the hex clockwise 45° until resistance is encountered. Then lift the key approx. 1/4" [7 mm] until the black socket for the key is level with the top of the housing cover. The spring mechanism will now rotate the key counter-clockwise and the plunger will retract.

② Manual operation

Turning the hex clockwise causes the plunger to extend to the required position.

③ Locking manual operation

Turn the hex 3/4 turn counter-clockwise and then press it down into the cover of the housing (the black socket will move inwards approx. 1/4" [7 mm]). Slight counter-clockwise rotation of the key will then lock the manual operating mechanism in position.

Note: Do not trigger the spring mechanism and turn the manual operating mechanism clockwise to the "spring-up" end position at the same time.

NVF24-MFT US

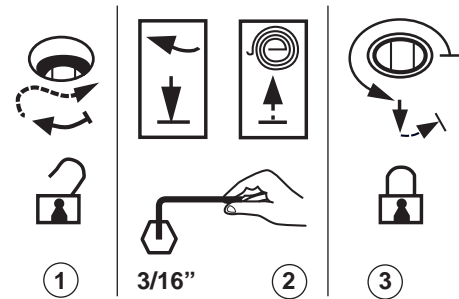

NVF...-E Extending, Spring Down

① Disengaging manual operation

Turn the hex counter-clockwise 45° until resistance is encountered. Then lift the key approx. 1/4" [7 mm] until the black socket for the key is level with the top of the housing cover. The spring mechanism will now rotate the key clockwise, the plunger will extend.

② Manual operation

Turning the hex counter-clockwise causes the plunger to retract to the required position.

③ Locking manual operation

Turn the hex back clockwise 3/4 turn and then press it down into the cover of the housing (the black socket will move inwards approx. 1/4" [7 mm]). Slight clockwise rotation of the key will then lock the manual operating mechanism in position.

NVF24-MFT-E US

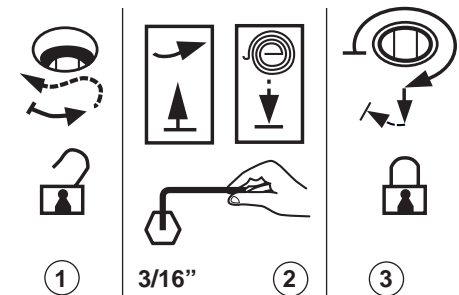

Operation/Installation

Functional description NV24-MFT US, NVF... US

The S1 button makes it simple to check the wiring and overall functioning of the actuator. The first time voltage is applied, the stroke is adapted automatically. Independently of this, an adaptation can be repeated as necessary by pressing button S2. Actuator will not do an adaptation after each power loss.

S1	Test	The valve performs full stroke at maximum running time and checks the adapted stroke.
S2	Adaptation	The stroke effected (between the two mechanical end-stops of the valve) is acquired as 100% stroke and stored in the microprocessor. The control signal and running time are then matched to this 100% stroke.

Set-Up of S3 switches

Note: It is very important to set Switches S3.1 and S3.2 to ensure proper valve operation.

- Determine if the valve body that is being retrofitted is STEM UP CLOSED or STEM UP OPEN. In other words, when is the valve closed from Ports A to AB– when the stem is up or down?

If the valve is STEM UP OPEN – set Switch S3.2 to the ON position

If the valve is STEM UP CLOSED – set Switch S3.2 to the OFF position

By setting this switch, the actuator will be able to recognize its closing point during the ADAPTATION process.

- Determine if you would like to valve to be Reverse or Direct Acting.

Direct Acting: if the valve should be CLOSED at minimum control signal – set Switch 3.1 to the OFF position.

Using this setting, the valve will be CLOSED at minimum control signal and will OPEN as the control signal increases. EX: Closed at 0 Volt signal and Open at 10 Volt signal.

Reverse Acting: if the valve should be OPEN at 2 Volts (or minimum control signal) – set Switch 3.1 to the ON position.

Using this setting, the valve will be OPEN at minimum control signal and will CLOSE as the control signal increases. EX: Closed at 10 Volt signal and Open at 2 Volt signal.

NOTE: The Feedback signal (Wire 5) of the NV Series actuator will follow the closing point of the valve- not the input control signal. In other words, the feedback will always read 2 Volts when the valve is closed regardless if the input control signal is set for Reverse or Direct Acting.

S3 Setting the direction of stroke and selecting the closing point

The stroke direction can be adjusted to be reverse or direct acting. Under the factory setting, the stroke increases as the setting signal increases. Depending upon the type of valve (NO/NC), the closing point (stroke = 0%) can be chosen with the valve stem retracted or extended.

S3.1	Direction of stroke	The direction of stroke is inverted in relation to the control signal
	Off position	Control signal = 0% corresponding to 0% stroke
	On position	Control signal = 100% corresponding to 0% stroke
S3.2	Selecting the closing point	This is the closing point of the valve. This is dependent on the valve body-not the actuator. This setting must be correct for proper operation of the actuator.
	Off position	Valve is stem up closed. (Flow from A to AB).
	On position	Valve is stem down closed. (Flow from A to AB).

EXAMPLES

S3.1	OFF	At 2 Volts, the valve is closed
S3.2	OFF	The valve closing point is STEM UP CLOSED.

Result of Input Signal and Feedback Signal: The valve will be closed at 2 Volts and will open as the actuator drives down. The control signal will read 2 Volts at the closed point and 10 Volts at the fully open point. The feedback will read 2 Volts at the closed point and 10 Volts at the fully open point.

S3.1	ON	At 2 Volts, the valve is open.
S3.2	OFF	The valve closing point is STEM UP CLOSED.

Result of Input Signal and Feedback Signal: The valve will be fully open at 2 Volts and will open as the actuator retracts. The control signal will read 10 Volts at the closed point and 2 Volts at the fully open point. The feedback will read 2 Volts at the closed point and 10 Volts at the fully open point.

S3.1	OFF	At 2 Volts, the valve is closed
S3.2	ON	The valve closing point is STEM DOWN CLOSED.

Result of Input Signal and Feedback Signal: The valve will be closed at 2 Volts and will open as the actuator retracts. The control signal will read 2 Volts at the closed point and 10 Volts at the fully open point. The feedback will read 2 Volts at the closed point and 10 Volts at the fully open point.

S3.1	ON	At 2 Volts, the valve is open.
S3.2	ON	The valve closing point is STEM DOWN CLOSED.

Result of Input Signal and Feedback Signal: The valve will be open at 2 Volts and will close as the actuator drives down. The control signal will read 10 Volts at the closed point and 2 Volts at the fully open point. The feedback will read 2 Volts at the closed point and 10 Volts at the fully open point.